

INTELLIGENT FAULT DIAGNOSIS OF ROTATING MACHINERY THROUGH VIBRATION ANALYSIS



By

Muhammad Masood Tahir

Reg. No. 38-FET/PHDEE/F10

A dissertation submitted to I.I.U. in partial fulfillment
of the requirements for the degree of

DOCTOR OF PHILOSOPHY

Department of Electrical Engineering
Faculty of Engineering and Technology

INTERNATIONAL ISLAMIC UNIVERSITY
ISLAMABAD

2017



Accession No TH: 18780 VM

PHD

621.31937

TAL

Artificial intelligence
Fault location (Engineering)
Detectors-

Copyright ©2017 by Muhammad Masood Tahir

All rights reserved. No part of the material protected by this copyright notice may be reproduced or utilized in any form or by any means, electronic or mechanical, including photocopying, recording or by any information storage and retrieval system, without the permission by the author.

DEDICATED TO

My parents, teachers, family and friends

CERTIFICATE OF APPROVAL

Title of Thesis: Intelligent Fault Diagnosis of Rotating Machinery through Vibration Analysis

Name of Student: Muhammad Masood Tahir

Registration No: 38-FET/PHDEE/F10

Accepted by the Department of Electrical Engineering, Faculty of Engineering and Technology, International Islamic University Islamabad (IIUI), in partial fulfillment of the requirements for the Doctor of Philosophy degree in Electronic Engineering.

Viva voce committee:

Prof. Dr. Muhammad Amir (Dean)

Faculty of Engineering and Technology, IIUI



Dr. Suheel Abdullah Malik (Chairman)

Department of Electrical Engineering, IIUI



Dr. Muhammad Usman (External Examiner I)

Director, AERO, Wah Cantt.

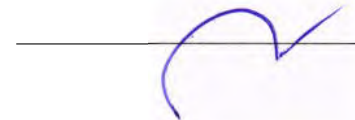

Dr. H. M. Faisal Zafar (External Examiner II)

Principal Scientist, PAEC, Islamabad

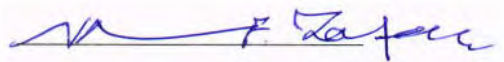

Dr. Ihsan Ul Haq (Internal Examiner)

Department of Electrical Engineering, IIUI



Dr. Ayaz Hussain (Supervisor)

Chairman, Department of Computer Science, IIUI

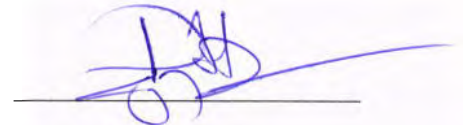

Dr. Saeed Badshah (Co-supervisor)

Chairman, Department of Mechanical Engineering, IIUI

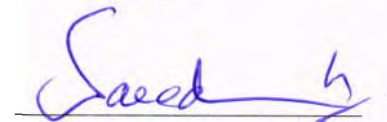

ABSTRACT

Complex rotating machines are extensively used in modern industry with high demanding performance. However, due to severe operating conditions, certain unexpected breakdowns may occur in the machinery that may be expensive and potentially catastrophic. This research addresses the early detection of common faults occurring in rotating machinery using supervised learning based pattern recognition (PR) methods.

The study focuses on obtaining the accurate and fault-related time domain (TD) statistical features, with the intention of enhancing diagnostic capability of classifiers. Localized faults in rolling element bearing (REB) generate very weak vibrations and the extracted TD features may be affected by unrelated fluctuations present in the vibration signal transmitted by joint machinery components. The inaccurate feature values may mislead classifiers and consequently reduce their fault classification accuracy. To deal with the issue, two new central tendency (CT) based feature processing and extraction methods are presented that adequately mitigate the affect of these fluctuations on the supervised learning based classification process. The methods helps to extract accurate and fault related features to improve the fault classification accuracy of the classifiers.

Unlike faults in REB, the most common faults in rotor, unbalance and misalignment, produce larger amplitudes in vibration signal. Yet, the reliable identification of these faults is often hard by using conventional frequency methods. Moreover, misjudging misalignment with unbalance fault may even aggravate the situation in machinery due to different maintenance strategies. Present research exploits

the difference of mechanical forces exhibited by these faults in multiple axes of the rotor, in terms of transmitted vibrations, for the extraction of very effective TD features. These multi-axis features are processed further to improve the fault classification accuracy of the diagnostic model.

Variety of classifiers are employed to evaluate the performance of the presented methods. The classifiers include support vector machine (SVM), bayesNet, decision table and decision tree. All the classifiers have shown considerable improvement in their fault classification accuracy. In case of REB's four faults, the achieved accuracy reaches to 96.8% from 76.3% obtained by using raw TD features. Similarly, in rotor's case, the fault classification accuracy is enhanced to 100% from 83.3% by using multi-axis TD features.

LIST OF PUBLICATIONS

- [1]. M. M. Tahir, A. Q. Khan, Naeem Iqbal, Ayyaz Hussain, Saeed Badshah, "Enhancing Fault Classification Accuracy of Ball Bearing using Central Tendency based Time Domain Features", IEEE Access, Vol.5, PP. 72 - 83, 2016. **(ISI indexed journal, impact factor 3.24)**

- [2]. M. M. Tahir, Ayyaz Hussain, Saeed Badshah, Qaisar Javaid "Rule-based Identification of Bearing Faults using Central Tendency of Time Domain Features", Journal of Engineering and Applied Sciences, Vol.35. No. 2, 2016. **(HEC recognized journal, X-category)**

- [3]. M. M. Tahir, Ayyaz Hussain, Saeed Badshah, "Enhancing Classification Accuracy of Ball Bearing Faults using Statistically Processed Features", IEEE International Conference on Intelligent Systems Engineering (ICISE), Islamabad, January 2016.

- [4]. M. M. Tahir, Ayyaz Hussain, Saeed Badshah, A. Q. Khan, Naeem Iqbal, "Classification of Unbalance and Misalignment Faults in Rotor using Multi-Axis Time Domain Features", IEEE International Conference on Emerging Technologies (ICET), Islamabad, October 2016.

- [5]. M. M. Tahir, Ayyaz Hussain, Saeed Badshah, "Accurate Extraction of Time Domain Features for Reliable Classification of Ball Bearing Faults", International

Journal of Advanced and Applied Sciences, Vol. 5. No. 1, PP. 156-163, 2018.

(ISI indexed journal)

ACKNOWLEDGMENTS

In the name of Allah, the most gracious and the most merciful. I would like to thank all the people who contributed in some way to this research. First and foremost, I would like to express my deep gratitude to my research supervisors Dr. Ayyaz Hussain and Dr. Saeed Badshah, for their valuable guidance, encouragement and useful criticism during every phase of my research work. I would like to offer my sincere thanks to Dr. Ulfat Jafri and Dr. Mohammad Imran for their never ending technical and moral support. Dr. Abrar Ahmed, Dr. Naeem Iqbal and Dr. Abdul Qayyum Khan, from Pakistan Institute of Engineering and Applied Sciences Islamabad, are thanked for providing me the technical guidance and moral support. Mr. Shahwaz Hussain and Mr. Waqas Shahid are thanked for their help in setting up experimental setup to acquire machinery data. I would like to thank Dr. Nader Sawalhi from Mohammad bin Fahad University, Saudi Arabia for his valuable comments. My fellow PhD scholars Dr. Zafarullah, Mr. Naveed Ishtiaq and Dr. Atif Elahi are deserved special thanks for the lively discussions that we carried out together. I would also like to acknowledge the facility provided by International Islamic University and my office to pursue my PhD studies. In the last but not least, Dr. Ijaz Mansoor Qureshi, Dr. Ihsan ul Haq, Mr. Abdul Rehman, Dr. Mureed Hussain, Mr. Ashfaq Ahmed, Dr. Saif-ur-Rehman, Mr. Shafiq-ur-Rehman, Mr. Ikramullah, Dr. Muhammad Afzal, Dr. M. M. Talha, Dr. Shahid Nisar, Dr. Ramazan Ali, Dr. Saleem Awan, Mr. Jamil Akhtar, Mr. Bashir Ahmed, Miss Saba Khalid, Dr. Yaseen Chohan, Mr. Abdul Sattar, Mr. Manzoor Hussain, Mr. Iftikhar Ahmad Awan, Mr. Khalid Hussain Khattak, Mr. Shoaib

Hassan Bukhari, Mr. Shahbaz Naseer, Mr. Zafar Altaf, Dr. M. Afzal and Dr. Farhad Ali, Dr. Mohammad Tasleem, Dr. Hamid Zaigham, Dr. Arif Noor, Mr. Asif Bhatti and Mr. Mohammad Asghar are thanked for their moral support. I am really grateful to my parents, brother and sisters for their love, moral support and prayers during every stage of my PhD study. I am also very thankful to my wife for her patience, encouragement and prayers to complete the task. Finally, I am grateful to my daughter and son, whose innocent gestures have been the source of my inspirations.

(Muhammad Masood Tahir)

Contents

List of Figures	xv
List of Tables	xvii
1 Introduction	1
1.1 Background	1
1.2 Research Problem	7
1.2.1 Bearing Fault Diagnosis	7
1.2.2 Rotor Faults Diagnosis	8
1.3 Philosophy of the Work	8
1.4 Research Hypotheses	8
1.5 Research Methodology	9
1.6 Contribution of the Research	10
1.7 Scope of the Thesis	12
1.8 Organization of the Thesis	13
2 Literature Review	14
2.1 Condition-based Maintenance	14
2.2 Common Faults in Rotating Machinery	17
2.2.1 Bearing's Localized Faults	17
2.2.2 Unbalance and Misalignment Faults in Rotor	20
2.3 Fault Diagnosis Approaches	23
2.4 Signal Processing based Fault Diagnosis	24
2.4.1 Time domain	25
2.4.2 Frequency Domain	26
2.4.2.1 Envelope Analysis	27
2.4.3 Time-Frequency Domain	28
2.4.3.1 Spectral Kurtosis	30
2.4.3.2 Order Tracking	31
2.4.4 Phase Analysis	32
2.5 Machine Learning based Diagnostics	32
2.5.1 Data Acquisition	33
2.5.2 Pre-Processing	33
2.5.2.1 Outlier Detection	34
2.5.3 Feature Extraction	35

2.5.4	Feature Selection	39
2.5.5	Pattern Recognition	40
2.6	Summary	43
3	Enhancing Fault Classification Accuracy of Ball Bearing using Central Tendency based Time Domain Features	45
3.1	Pre-Processing	46
3.2	Experimental Setup	48
3.2.1	Data Validation	48
3.3	Materials and Methodology	50
3.3.1	Vibration Data Samples and Feature Extraction	50
3.3.2	CT-based Feature Processing (CTBFP)	50
3.3.2.1	Outlier Detection	51
3.3.2.2	Instance Pruning	53
3.3.3	Fault Classification	53
3.3.3.1	SVM	54
3.3.3.2	BayesNet	55
3.3.3.3	Decision Table	57
3.3.3.4	Decision Tree	58
3.4	Results and Discussion	58
3.5	Summary	63
4	Extracting Accurate Time Domain Features from Vibration Sig- nals for Reliable Classification of Ball Bearing Faults	65
4.1	CTBFE Technique	66
4.2	Proposed Methodology	66
4.2.1	Vibration Data Acquisition	67
4.2.2	CT-based Feature Extraction (CTBFE)	68
4.2.2.1	Data Segmentation	69
4.2.2.2	TD Feature Extraction from the Segments	70
4.2.2.3	Obtaining CT of the Features	70
4.2.3	Fault Classification	71
4.3	Results and Discussion	71
4.4	Summary	75
5	Rule-based Identification of Bearing Faults using CTBFE method	76
5.1	RBDS Methodology	77
5.1.1	Feature Selection	77
5.1.2	Rule Formation and Decision Making	80
5.2	Results and Discussion	81
5.3	Summary	83
6	Classification of Unbalance and Misalignment Faults in Rotor us- ing Multi-Axis Time Domain Features	84

6.1	Rotor Faults	85
6.2	Proposed Methodology	86
6.2.1	Data Acquisition	86
6.2.2	Multi-Axis TD Feature Extraction	87
6.2.3	Feature Processing	87
6.2.4	Fault Classification	88
6.3	Results and Discussion	89
6.4	Summary	91
7	Conclusions and Future Work	93
7.1	Future Work	96
	References	98

List of Figures

2.1	Condition monitoring parameters	15
2.2	Structure and basic frequencies in ball bearing	18
2.3	Unbalance in single-plane	20
2.4	Types of misalignment	22
2.5	Model based diagnostics	23
2.6	Envelope analysis procedure	27
2.7	Pattern recognition process	33
2.8	Feature extraction domains	36
2.9	Supervised learning based pattern recognition	42
3.1	Schematic of experimental setup	48
3.2	Enveloped spectra of the bearing faults	49
3.3	Block diagram of CTBFP-based fault diagnosis of ball bearing	50
3.4	Median as central tendency measure	51
3.5	Parameters of Box plot	52
3.6	Supervised learning and fault classification procedure	54
3.7	Margin and support vectors in SVM	55
3.8	A simple Bayesian network	56
3.9	Waveforms of IR and OR faults	59
3.10	Enveloped Spectra of the segments Seg_{AB} and Seg_{BC} of OR waveform	59
3.11	Feature processing via MOD	60
3.12	Outlier detection via Box Plot	61
3.13	Sensitivity of the features against OR fluctuations	62
3.14	Skewness feature processing	63
3.15	Variance feature processing	63
4.1	Block diagram of CTBFE-based fault diagnosis of ball bearing	67
4.2	Schematic of experimental setup	68
4.3	Enveloped spectra of bearing's faults	69
4.4	CT-based Feature Extraction of single feature	69
4.5	Shape Factor feature extracted from every faulty signal	70
4.6	Waveforms of bearing faults	72
4.7	Distribution of features for every faults, using conventional feature extraction and CTBFE methods	73
5.1	Block diagram of the RBDS	77

5.2	Flow chart of a feature evaluation procedure	78
5.3	Relative distances among respective NCVs of every feature	79
6.1	Block diagram of Multi-axis features based fault diagnosis of rotor .	86
6.2	Schematic of the experimental setup	87
6.3	Spectra of rotor faults	87
6.4	Fault classification procedure	89

List of Tables

2.1	Typical problems treated by vibration analysis [1]	16
3.1	Bearing fault frequencies along with the central frequencies and bandwidths (Hz)	49
3.2	Sample instances containing marked outliers as 99.999	53
3.3	Layout of decision table	57
3.4	Individual accuracies of the features before and after processing, using SVM, BayesNet, Decision Table and Decision Tree classifiers :	61
4.1	Fault frequencies of bearing	68
4.2	Fault classification accuracies (%) demonstrated by the classifiers using TD features extracted through conventional method, CTBFP method and CTBFE method	73
4.3	Sample instances	74
4.4	Comparison of the influence of background noise on SVM classification accuracy (%)	75
5.1	Minimum distances between any pair in a set of NCVs	80
5.2	Vibration data samples used for RBDS, and for SVM model	82
5.3	Effect of background noise on the fault classification accuracies (%) from RBDS and SVM	83
6.1	Classification accuracies (%) demonstrated by SVM using radial, axial and multi-axis TD features	90
6.2	Classification accuracies (%) demonstrated by every classifier using * radial, axial and multi-axis TD features	91

Chapter 1

Introduction

This chapter begins with background knowledge of the subject and provides an overview of the common faults occurring in rotating machinery and conventional diagnostic techniques. This is followed by the motivation behind the research, detailed description of the research problem and the resulting contributions. Finally, the chapter describes the structure of thesis.

1.1 Background

Modern rotating machinery is part of almost every industry that require efficient, economical and safe production. However, the machinery works generally under severe operating conditions, which may cause sudden breakdowns and decrease of performance. This may result in financial losses, lower products quality and operation safety. Undetected malfunctions of machine components can also induce failures in the related parts. Lack of timely available factual data, used to quantify the actual need of maintenance, is often the main reason behind ineffective maintenance management [1]. Therefore, early detection and diagnosis of complex machinery faults is crucial for economical and safety reasons.

Condition-based maintenance (CBM) methods offer early prediction of machinery faults using condition monitoring (CM) technologies [2]. Recent advancements in

sensors, instrumentation, communication and computation provide the means to manage this kind of maintenance operations. The CM procedures cover different disciplines, such as mechanical measurements, electrical measurements, performance or process measurements, tribology and non-destructive testing [3]. Typical parameters of mechanical measurements include vibration, acoustic emission, temperature and strain. Among all, vibration measurement and analysis has been the most common and popular approach [1]. The vibration parameter can address majority of machinery faults and provides an earliest indication of any developing fault. The parameter provides a clear picture of plant's health, making it possible to prior plan maintenance activities for those machines which have signs of any potential failure. Mechanical systems produce vibration even when they are new or operating properly. However, the vibration level is very small and constant in that case, but the signature changes quickly with the development of some fault. Machinery failures reveal a chain reaction of cause and defect. The fault diagnosis works backwards to define the elements or root causes of the chain involved in the failure. The root cause analysis also prevents the machinery from suffering the same fault again and again.

Basic components of rotating machinery include bearings, gears, fans, rotors and shafts. The most common of them is rotor-bearing mechanism. Bearing is very critical component due to bearing basic dynamic loads and forces. Faults in rolling element bearing (REB) are common and categorized into distributed and localized faults. Typical distributed bearing faults include surface roughness, waviness, misaligned races and off-size rolling elements. These are usually caused by design and manufacturing errors, improper mounting, wear and corrosion etc [4]. Localized bearing faults include cracks, pits and spalls on the rolling surfaces that are usually caused by plastic deformation, brinelling and material fatigue [5, 6]. Both distributed and localized bearing faults can cause machinery malfunctions. From the standpoint of health monitoring of machinery, however, localized fault diagnosis is more important as spalling of races or rolling elements having dominant style of failure. Moreover, in real world applications, many distributed faults originate from localized spalling [7]. Common rotor faults include unbalance, misalignment,

rub, bent, oil whirl and pedestal looseness [8]. Unbalance and misalignment are the most common and frequently occurred faults. As many problems associated with the machinery are attributed to bearing failures and faulty rotor, the present research focuses on the study of localized faults in REB and most frequently occurring faults in rotor.

There exist two principal approaches to machinery fault diagnosis, known as model-based approach and data-driven approach [9]. The model-based approach uses an analytical model of a process to analyze the systems dynamic behavior. The mathematical model usually involves time dependent differential equations, where deviations from the expected values of monitoring parameter represent the health state of machinery. However, inappropriately designed models can cause false diagnostics. Hence, data-driven techniques are an alternative where analytical model is not feasible. In data-driven techniques, informative data is collected from a system under test to implement appropriate analysis. Several methods have been developed in data-driven domain using vibration data for fault diagnosis of rotating machinery. These methods mainly include signal processing, fuzzy systems, artificial intelligence (AI) based pattern recognition (PR) and expert systems.

As the CBM strategy is fully supported by computer technology, the recent advancements utilizes AI techniques as well-adopted tool [10]. Intelligent maintenance systems can make inferences and arrive at reliable conclusion. In this regard, supervised learning based PR is an emerging and useful technique for such situations. Main stages to recognize the fault patterns are feature extraction, feature selection and fault classification. Extraction of appropriate diagnostic features is very important for reliable PR process. The feature extraction stage mainly utilizes signal processing methods, such as time domain (TD), frequency domain (FD) and time-frequency domain (TFD). Although TD vibration signals contains mixture of frequency components transmitted by machine parts, principal advantage of TD analysis is that almost no data is lost in transformations. The signal is often characterized using some statistical parameters or features. These features can be compared with pre-defined thresholds to detect machinery faults and

for tracking their deterioration. Usually, the features involve indices, which are sensitive to impulsive oscillations in vibration signal. Several TD statistical features are reported in the literature used for PR of machinery faults, such as root mean square (RMS), mean, standard deviation (SD), variance, skewness, kurtosis, crest factor (CF), impulse factor (IF), shape factor (SF), median, range etc. The features are described below.

- **RMS:** The RMS is the normalized second statistical moment of a signal and commonly used to quantify the steady state signal. In vibration analysis, RMS describes the energy of the signal and is used for fault detection as a most basic and important feature.

$$RMS = \left(\frac{1}{N} \sum_{i=1}^N [X(i)]^2 \right)^{\frac{1}{2}} \quad (1.1)$$

- **Mean:** This is the first moment of probability distribution of a signal and provides an average value of the signal.

$$Mean(\mu) = \frac{1}{N} \sum_{i=1}^N X(i) \quad (1.2)$$

- **Standard Deviation:** The SD is used to quantify the amount of variation or dispersion of a set of data values. The following relation calculates its value.

$$StandardDeviation(\sigma) = \left(\frac{1}{N} \sum_{i=1}^N (X(i) - \mu)^2 \right)^{\frac{1}{2}} \quad (1.3)$$

- **Variance:** This measure is the second moment of probability distribution of a signal, and reflect that how far a set of numbers is spread out from its mean.

$$Variance(\sigma^2) = \frac{1}{N} \sum_{i=1}^N (X(i) - \mu)^2 \quad (1.4)$$

- **Skewness:** The feature is the third statistical moment that characterizes the degree of asymmetry of data distribution around its mean.

$$Skewness = \frac{1}{N} \sum_{i=1}^N \left(\frac{(X(i) - \mu)}{\sigma} \right)^3 \quad (1.5)$$

- **Kurtosis:** This is the fourth normalized statistical moment, which indicates the flatness or the spikiness of a signal. The feature is being extensively used for bearing's fault diagnosis.

$$Kurtosis = \frac{1}{N} \sum_{i=1}^N \left(\frac{(X(i) - \mu)}{\sigma} \right)^4 \quad (1.6)$$

- **Crest Factor:** Measuring RMS level is the simplest approach to detect faults in TD. However, this may not show appreciable changes at the early stages of faults. The CF may be more sensitive to this situation as it is defined as the ratio of the peak level of the input signal to its RMS level. Therefore, peaks in a TD signal due to impulsive vibrations may result in an increase in the CF, which can help to detect any possible changes in the signal's pattern.

$$CrestFactor = \frac{\max(|X|)}{RMS} \quad (1.7)$$

- **Impulse Factor:** The IF is defined as the ratio of the peak level of an input signal to its absolute average, and is also sensitive to shape of peaks generated due to fault impacts.

$$ImpulseFactor = \frac{\max(|X|)}{\frac{1}{N} \sum_{i=1}^N |X(i)|} \quad (1.8)$$

- **Shape Factor:** The SF is defined as the ratio of the RMS level of the input signal to its absolute average.

$$ShapeFactor = \frac{RMS}{\frac{1}{N} \sum_{i=1}^N |X(i)|} \quad (1.9)$$

- Median: This measure is the middle score of elements present in a data set when arranged in ascending or descending order. The following formula is used to calculate the median, when N is odd number of elements in the data set.

$$Median = magnitude\left(\frac{N + 1}{2}\right) \quad (1.10)$$

However, if the number of elements is even, then the median is calculated by averaging the two middle elements.

- Range: The feature is the measure of peak to peak vibration and can be used to detect the severity of spikes generated from machinery fault sources.

$$Range = max(X) - min(X) \quad (1.11)$$

In the above relations, X is the sequence of data samples obtained after digitizing time domain vibration signals, $X(i)$ is the amplitude of i^{th} sample and N is the total number of data samples in the sequence.

Although the PR is a popular domain for automatic diagnosis of machinery faults, noise in the systems often misleads the statistical classifiers in their training phase [11]. Thus, to facilitate the fault detection process, most of the existing fault diagnosis methods involve certain pre-processing of raw TD vibration data before further analysis. The data pre-processing normally includes extraction of appropriate frequency range [12–17] and noise reduction [18–23]. Literature reports numerous vibration-based PR methods have so far been employed to detect faults in rotating machinery using TD statistical features. However, maintaining an optimum fault classification accuracy using a minimal set of features has been a challenge.

1.2 Research Problem

Rotating machinery components produce complex vibration signals. Problem arises, when vibration produced by a faulty component is influenced by the vibrations generated from multiple components in rotating machinery. Analysis of low amplitudes present in captured vibration signal then becomes very hard. On the other hand, TD features may be very useful for the recognition of faults in rotating machinery but are often sensitive to the undesired vibrations. Inaccurate and unrelated feature values may mislead the supervised learning based classifiers and consequently reduce the fault classification accuracy.

Very little work has been carried out regarding the accurate extraction of diagnostic features for machinery fault diagnosis. Signal quality along with machines operating conditions like load, speed, or torque can affect a feature's value [24, 25]. Difficulty with the existing methods is their complexity and computational cost, especially employing TD features. This study investigates faults in two diverse components of the rotating machinery, REB and rotor, with the intent to obtain accurate and fault-related TD features.

1.2.1 Bearing Fault Diagnosis

Identification of the localized faults in REB is very hard due to presence of very low amplitudes in captured vibration signal, which is often influenced by joint machine components like rotor or gear. Thus, the spectra of raw vibration signal contain very little diagnostic information regarding the bearing faults [2]. The common faults include inner race (IR) fault, outer race (OR) fault, ball (BL) fault and mixture of the above mentioned faults (MX). Numerous vibration-based PR methods have so far been employed to detect the bearing faults using TD statistical features [26–35]. However, the fault classification accuracy achieved is not at the satisfactory level. Our initial investigations show that the random nature of vibration signal can contain spikes or fluctuations, which may occur due to change in dynamic operating conditions in the machinery. Nevertheless, the

fluctuations may not be associated with the REB's localized faults and produce abnormal values or outliers in the extracted TD statistical features.

1.2.2 Rotor Faults Diagnosis

Unlike the bearing faults, the most commonly occurring faults in rotor, unbalance and misalignment, produce larger amplitudes in the transmitted vibration signal. Yet, the faults are very difficult to identify using conventional frequency methods due to exhibiting similar sort of spectra [8, 36]. On the other hand, accurate identification of these faults is extremely important as the rotor balancing procedure is based on attachment or removal of certain amount of weight to or from a particular location of the rotor. Thus, confirming the unbalance state of rotor is crucial prior to take any corrective action [37]. Misjudging misalignment with unbalance fault may even aggravate the situation in machinery. The literature shows that mostly single-axis vibrations, specially from radial axis, have been utilized to extract TD features for the purpose [8, 35]. These TD features may not be able to demonstrate properly the dissimilarity of exhibited forces by the rotor faults.

1.3 Philosophy of the Work

Taking into account the dynamics of machinery components, intelligent extraction or processing of the TD features may help to obtain accurate and fault related features. The extraction or processing methods may vary according to the mechanical design of a component, the nature of its faults and transmitted vibrations.

1.4 Research Hypotheses

Below are the research hypotheses formulated to obtain accurate and fault-related TD features. Hypothesis-1 addresses the classification of the bearing faults, whereas Hypothesis-2 addresses the faults in rotor.

Hypothesis-1 While diagnosing REB's localized faults, the acquired vibration signal may be affected by stronger impacts from joint machinery sources such as rotor or gear. This may alter the statistical values of the extracted TD features and consequently mislead a supervised learning based classifier. Isolating the external sources from the bearing at feature level or feature-extraction-level may provide accurate and fault related TD features.

Hypothesis-2 Utilization of the TD features, extracted from simultaneously acquired vibration signals, from multiple axes of rotor, may help to identify its unbalance and misalignment states accurately. The multi-axis features may be more sensitive due to the exhibition of dissimilar forces by these faults. The respective sensitivities of the features may be utilized intelligently for obtaining accurate and fault related features.

1.5 Research Methodology

The present research is of experimental nature that proposes solution to an immediate problem. To address the research hypotheses, several experiments are performed and the results are analyzed to derive conclusions. The research has been conducted in three main phases.

In the first phase, the research problem has been formulated to write-up a research proposal. Formulation of the research problem is comprised of literature review, defining the problem and identifying the research gap.

Second phase of the research deals with the planning. Reliable data collection procedures and data validation process are the main steps of this phase. The experimental data contains data-sets of the bearing and rotor faults. Details of the data-sets is described below.

1. To obtain data-sets from bearing faults, a mechanical testbed known as machine fault simulator (MFS) is utilized along with a set of faulty bearings

containing localized faults. The PC-based vibration measurement system contains 24-bit data acquisition hardware from National Instruments (NI). (Chapter 4 and Chapter 5).

2. Bearing data from Curtin University (CU) is also utilized for in-depth analysis of the bearing faults. The data is freely available online (Chapter 3).
3. To obtain data-set from faulty rotors, again the MFS is used. Rotor misalignment and unbalance faults are generated in controlled environment repeatedly (Chapter 6).

The final phase concerns about conducting the research that include processing of the data and writing of the thesis. Based on the observations from comprehensive experiments, new methods have been presented to solve our research problem. The data processing and analysis stage encompasses the experimental study to evaluate the presented methods. NI's LabVIEW along with its Sound and Vibration Measurement Suite and Matlab are the mainly used software packages for the purpose. Finally, the thesis concludes the research.

1.6 Contribution of the Research

The thesis fills a significant research gap by studying the role of accurate TD diagnostic features for supervised learning process. The reliable and accurate TD features obtained through these methods have been found robust and provide higher diagnostic information to PR-models. Therefore, the present research emphasizes the use of intelligently processed TD features for the problem at hand, instead of using raw features. A substantial advantage of the proposed extraction and processing of the features over conventional pre-processing of raw vibration data is the computational cost. Only few values in feature distributions are required to be processed rather than processing the huge vibration data. Several classifiers are used to evaluate the performance of the presented methods. These

classifiers include support vector machine (SVM) [38], bayesNet [39], decision table [40] and decision tree [41]. Classification accuracy of all the classifiers has been enhanced considerably when applied the proposed methods. Major contributions of the research include:

1. A central tendency (CT) based feature processing (CTBFP) method is developed prior to supervised learning based classification process to identify localized faults in REB. The CTBFP method processes the features at data preparation stage of instance formation. The method deals adequately with the possible feature outliers and ensures the supply of only fault-related feature values to classifier by discarding the affected instances. The fault classification accuracy of the classifiers is improved considerably. In addition to computationally efficient, the method is immune to possible fluctuations present in vibration signals. The CTBFP method produces 94.4% accuracy at maximum using multi-class SVM to identify four faults of REB employing ten TD features. Using the same vibration data set, the classifier could provide only 76.3% accuracy when employed the same raw TD features.

2. Application of the CTBFP method may become somewhat limited when training data-set is small, due to the strategy of discarding the affected instances. Unlike processing the feature distributions at feature-level, a new CT-based feature extraction (CTBFE) method is presented that works at feature-extraction-level to obtain reliable TD feature values to recognize the fault patterns of REB. The presented method selects the most appropriate portion of a vibration signal for the extraction of features. The CTBFE method not only preserves number of instances but also provides more accurate results compared to that of aforementioned CTBFP method. The method is efficient and provides significant immunity to possible fluctuations and background noises present in vibration signals. The CTBFE demonstrates 96.8% accuracy at maximum using multi-class SVM to identify four faults of REB employing ten TD features.

3. The CTBFE is exploited further to develop a rule-based bearing diagnostic

system (RBDS). Each TD feature is processed statistically to approximate its precise central values (CVs) against the respective faults. In this way, every feature provides a set of CVs that are equal in number to that of faults. Separating distances among normalized CVs (NCVs) in a set allow to select or discard that particular feature before further processing. The selected features or sets of NCVs are finally used as references to generate rule-set for testing the unknown samples. The results from RBDS are evident that the proposed method may be an effective alternative to the existing classifier-based costly fault diagnosis, even in the presence of strong background noise. Using the same vibration data set, the RBDS produce 95.6% accurate results employing only three salient features.

4. Multi-axis TD features are employed for accurate identification of unbalance and misalignment faults in rotor. Every pair of alike features is then further processed to have more effective feature to take part in the PR process, i.e. RMS-radial and RMS-axial are processed adequately to produce a single robust RMS feature. Multi-axis implementation of the TD features also maintains the length of the feature vector for efficient data processing, in addition to providing very accurate results. The method enhances the accuracy of binary-SVM model to 100% using six multi-axis features only. The classifier provides only 83.3% classification accuracy employing the same but single axis TD features.

1.7 Scope of the Thesis

The present research utilizes only the TD features for the machinery problems at hand, using supervised learning based PR methods. Sensitivity of the TD features is investigated for the localized faults in REB and rotor's unbalance & misalignment faults. This study does not cover the physical causes or mechanical phenomena behind the occurrence of random fluctuations in vibration signals during the faults diagnosis of bearing. Similarly, the study does not cover the rotor dynamics or generation of vibratory forces by the rotor faults under study.

1.8 Organization of the Thesis

Chapter 2 provides critical literature review, which focuses on rotor and bearing transmission system and its fault diagnosis using signal processing and vibration-based PR methods.

Chapter 3 describes the CTBFP method used to identify localized faults in REB. The chapter also deliberates the generation of outliers, their detection criteria and discarding procedure of the affected instances. Sensitivity level of the TD features is investigated against the random fluctuations in vibration signal. Finally, the noise immunity of the CTBFP method is discussed.

Chapter 4 describes the CTBFE method to classify again the localized faults in REB. Accurate extraction of the TD features is demonstrated for trustworthy performance of the classifiers. The performance of the presented method is compared with that of CTBFP method.

Chapter 5 sheds light on the RBDS method to diagnose REB's faults. The algorithm explains the utilization of CTBFE-based feature values to develop rule-based mechanism.

Chapter 6 describes the rotor's faults. The chapter explains the extraction of multi-axis features and their processing according to the nature of faults to obtain robust feature-set for trustworthy diagnostics.

Chapter 7 concludes the research work and suggests some future work.

Chapter 2

Literature Review

The chapter covers a wide range of literature that includes rotating machinery, maintenance methods and vibration-based fault diagnostic techniques. After a preliminary literature search, the literature review focuses on fault diagnosis of rotor and bearing using vibration-based PR methods.

2.1 Condition-based Maintenance

Maintenance is a combination of science, art, and philosophy [42]. The activity is carried out to restore a faulty machine to working condition. Efficient maintenance activity is a matter of having right the resources to be used at the right time. Maintenance methods are broadly categorized into three main categories [1], and each one has its own associated costs and benefits. The most expensive and oldest maintenance method is breakdown or failure method [43], which is carried out after a fault occurs. This often results in immediate halt of running process and plant downtime. Apart from costly replacement of machinery components, the situation can be catastrophic to workers. Preventative maintenance [44] is the next logical method, which relies on periodic replacement of machinery components at fixed-time calculated on their life-basis, even they are working properly. This method usually has lower associated cost relative to the breakdown method as

inventory and manpower can be better planned. The most advanced, logical and cost effective method is predictive maintenance or CBM, in which maintenance activity is carried out on the basis of condition of machinery parts [2]. As soon as a machine begins to exhibit signs of incipient failure, CBM allows to plan its inventory and repair schedule. The method also contributes to improve worker's health and safety as the developing fault may produces pollution or health hazards. Moreover, the CBM is also used to check a newly installed machine before start-up, in terms of its foundation, stability, proper alignment and overall integrity [45].

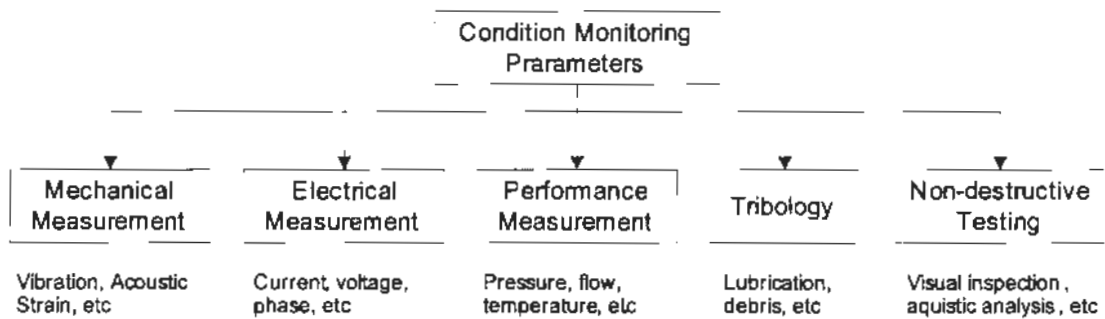

FIGURE 2.1: Condition monitoring parameters

Advanced CM technologies or parameters provides the basis to implement CBM. The CM technologies cover different disciplines such as mechanical measurements, electrical measurements, performance and process measurements, tribology and non-destructive testing, as shown in Figure 2.1. Typical parameters of mechanical measurements include vibration, acoustic emission and strain [46]. A CBM system mainly includes measurement hardware and software to acquire and interpret signals generated by the machine parameters being monitored. The system can perform on-line, i.e. when the machine is in operation as well as off-line. Jardine et al [3] presented a detailed review of the subject.

Among all the above mentioned parameters, vibration measurement and analysis has been the most common and popular. Vibration can addresses majority of the machinery faults, as shown in Table 2.1. The parameter is also an earliest indicator of any developing fault. Vibration provides a clear picture of plant's health, and allows to plan the maintenance schedule for those machines only that have signs of failures. Mechanical systems produce vibration even if they are new

TABLE 2.1: Typical problems treated by vibration analysis [1]

Item	Faults
Rotor and shaft	Unbalance Bent shaft Eccentricity Misalignment Rubs Cracked shaft Critical speeds Resonance Blade problems
Rolling element bearing	Pitting of roller or races Spalling Other defects in rolling elements
Journal bearing	Oil whirl Oval or barreled journal Journal/bearing rub
Flexible coupling	Unbalance Misalignment
Electrical machines	Damaged rotor bars Unbalanced magnetic pulls Air gap variations Foundation and structural faults Piping resonance Structural resonance Vortex shedding

or operating properly. However, the vibration level is very small and constant in that case. But the vibration signature changes quickly with the development of some fault. Failures in machinery reveal a chain reaction of cause and defect. The fault diagnosis procedure works backwards to define the elements or root causes of the chain involved. The root cause analysis also prevents the machinery from suffering the same fault again and again. Chenxing Sheng et al [47] discussed the most recent progress in the CM of machinery and vibration-based fault diagnosis.

2.2 Common Faults in Rotating Machinery

Basic components of rotating machinery include bearings, gears, fans, shafts or rotors. The rotor-bearing mechanism is the most common part of the machinery. As rotors runs on bearings, making the bearing very critical component due to bear basic dynamic loads and forces. Many problems associated with the machinery are attributed to faulty rotor and bearing failures. Therefore, the present research focuses on the study of frequently occurring faults in rotor and bearing.

2.2.1 Bearing's Localized Faults

Basic purpose of bearing is to provide an interface between the stationary and the rotating parts of a machine. Bearings provide a nearly frictionless support to guide rotors or shafts. Even well maintained bearings are subjected to at least one cause of failure that is its material fatigue [42]. There exists two general types of bearings, the journal hearing and the REB. For lower speeds and lighter loaded machines, the REB is the popular choice. Faults in REB are categorized into distributed and localized category. Typical distributed faults include waviness, surface roughness, off-size rolling elements and misaligned races. They are usually caused by design and manufacturing errors, improper mounting, wear, and corrosion [4]. Localized bearing defects include cracks, pits, and spalls on the rolling surfaces. These type of faults are usually caused by plastic deformation, brinelling, and material fatigue [5, 6]. Both distributed and localized bearing faults can cause machinery malfunction. However, from the standpoint of health condition monitoring, localized defect diagnostics are more important as spalling of races or rolling elements is the dominant style of the failure of REBs. Additionally, in real world applications, many distributed faults originate from a localized spalling [7, 48]. Tandon et al [7] reviewed vibration and acoustic measurement methods for the detection of defects in REBs.

Localized faults can be very small and difficult to detect. But these faults can reduce the life of bearing and may have a considerable impact on vibration-critical

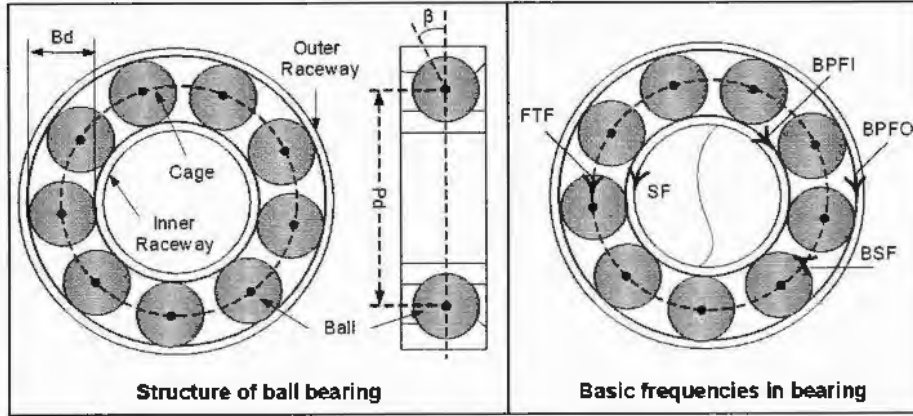

FIGURE 2.2: Structure and basic frequencies in ball bearing

machines. When a localized fault appears on the surface of any element of REB, cyclical impulsive vibration is originated consequently. For example, an impact is produced when the rolling elements strike a local fault present on inner or outer race, or any faulty rolling element strikes the races. Frequency of the impulsive vibration is known as characteristic or fault frequency, the value of which depends on the fault size, rotational speed and location of the faults. The fault frequencies mainly include fundamental-train-frequency (FTF), ball-pass-frequency of inner race (BPFI), ball-pass-frequency of outer race (BPFO), and ball-spin-frequency (BSF). Figure 2.2 shows the geometric parameters of REB that involve to generate the fault frequencies. Although the fundamental fault frequencies are expressed by simple formulas, but they are often complicated due to the presence of other sources of machinery vibration. With stationary OR and rotating IR, the fault frequencies are derived using bearing's geometry. Below is the mathematical description of the aforementioned frequencies.

$$FTF = \frac{SF}{2} \left(1 - \frac{B_d}{P_d} \cos\beta \right) \quad (2.1)$$

$$BPFI = \frac{N_b \times SF}{2} \left(1 + \frac{B_d}{P_d} \cos\beta \right) \quad (2.2)$$

$$BPFO = \frac{N_b \times SF}{2} \left(1 - \frac{B_d}{P_d} \cos\beta \right) \quad (2.3)$$

$$BSF = \frac{SF \times P_d}{2 \times B_d} \left(1 - \left(\frac{B_d}{P_d} \right)^2 \cos^2\beta \right) \quad (2.4)$$

Where SF is the motor driving frequency or rotational frequency of shaft, N_b is the number of balls, B_d is the diameter of ball, P_d is the pitch diameter and β is the ball's contact angle.

An IR fault generates a series of high energy vibration pulses, the rate of which is equal to the ball pass frequency relative to IR. As the IR is rotating, the fault will enter and leave the load zone during the rotation. As a result, the magnitudes of pulses will be large within the load zone and smaller out of the zone. This phenomenon produces a vibration signal that is amplitude-modulated at IR rotational frequency. The spectrum of signal not only gives rise to a discrete peak at the ball pass carrier frequency or BPFI but also produces pair of sidebands. The amount of each sideband will equal to the modulating frequency or SF or rotational frequency of IR. As the size of fault increases, magnitude of the FBFI increases as well as more sidebands can be generated. An OR fault generates a series of high energy vibration pulses, rate of which is equal to the ball pass frequency relative to the OR. As the OR is stationary, the amplitude of generated pulses will theoretically remain same. The spectrum of signal will then show a single discrete peak at BPFO. The transmission path of vibration signal from a faulty IR to sensor position mounted at bearing's housing is complicated, therefore fault on the OR usually easier to detect. Fault on the rolling element can generate a vibration signal containing BSF, along with the harmonics at FTF. Twice the BSF can also be generated as the fault strikes both raceways during single rotation. The BSF can also be amplitude-modulated at the FTF as the fault enters and leaves the load zone at the rate of FTF. This cause the sidebands in the spectrum around the BSF.

The amplitude of generated signal may be very low as the rolling element is not always lies in the load zone when the fault strikes. Energy is also lost during the propagation of vibration signal through the structural interfaces to sensor. When the defect is orientated in the axial direction it will not strike the IR or OR. Due to the above mentioned reasons, the rolling element or ball fault is usually very difficult to detect. Unlike raceway faults, cage defects do not excite specific fault frequencies usually. The vibration signal is likely to have random bursts as

However, Jordan [55] discussed that the misalignment fault initially affects the 1X response causing an elliptical shape of XY-orbit. They proposed two distinct approaches, forces at the couplings were identified in the first approach while in the second one the bearing loads are identified. Patel et al [56] discussed the effect of parallel and angular misalignment in coupled rotor on its vibrational behavior. With the help of an experimental setup, they investigated vibrations in bending, torsional, longitudinal modes. The spectral analysis revealed that 1X vibration component was stronger in axial direction from parallel alignment than that of angular alignment.

2.3 Fault Diagnosis Approaches

There exist mainly two approaches for fault diagnosis, model-based and data-driven [9]. Model-based approaches [57, 58] create explicit mathematical model of a system under investigation. This approach can be effective if an accurate model is built. However, it is very difficult to build models for complex systems.

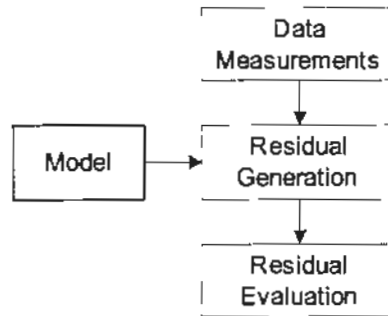

FIGURE 2.5: Model based diagnostics

Figure 2.5 shows main phases of model-based fault diagnosis approach; residual generation and residual evaluation. A residual is obtained at first stage by comparing available system measurements with priori information. At second stage, the generated residual is evaluated and fault is determined by applying any decision rule such as a threshold test. A generated residual acts as fault indicator to reflect condition of the system under investigation. A detailed review of model-based fault diagnosis is referred to [59]. Various model-based fault diagnosis are

applied of rotating machinery such as bearings [60, 61], rotors [36, 62, 63] and gearboxes [64]. Generally, conventional statistical signal processing methods treat vibration random signals as statistically stationary. But in cases where multiple periodicities are involved, the randomness can also be modeled as cyclostationary [65], i.e. time-varying statistical parameters with single or multiple periodicities.

Data-driven based signal processing methods have extensively been applied for the purpose of faults diagnosis of rotating machinery. These techniques are classified on the basis of type of signals or CM parameters, such as acoustic signal analysis, temperature measurement, lubricant analysis, electrical current analysis, and vibration measurement. Next section provides the details.

2.4 Signal Processing based Fault Diagnosis

Literature reports several signal processing based techniques to process various CM parameters. Monitoring the temperature of a bearing housing or lubricant is the simplest method for fault detection in rotary machines. Bearing distributed defects generate excessive heat in the rotating components that can be used to detect their health [66]. Debris analysis detects the presence of metallic particles in the lubricant [67]. The analysis of the various kind of metallic elements can also facilitate to find the location of the fault. Operating conditions of machinery also monitored by analyzing the motor current. Changes in the electric signals in the machinery can be associated with the health of mechanical components [68]. Acoustic emission is a transient impulse generated by solid material under mechanical or thermal stress due to the rapid release of strain energy [69]. Crack detection is the prime application of acoustic emission. Acoustic analysis is also used to detect bearing faults and shaft cracks. Accuracy of these methods typically depend on the sound intensity. Since abnormal vibration of rotating machinery is the first indicator component failure, the vibration measurement and analysis has been widely used in various kind of industries. Tandon et al [7] reviewed the

vibration and acoustic measurement methods to detect faults in REBs. Vibration-based signal processing can be performed mainly in TD [70], FD [71] and TFD [72].

2.4.1 Time domain

Simple statistical parameters, evaluated over the measured TD signal, can provide some interesting information about potential faults in the machinery. The TD analysis is directly based on the time waveform acquired from sensor, i.e.e vibration signal from bearing casing. The simplest technique is the visual inspection of specific portions of a time waveform. Principal advantage of TD analysis is that almost no data is lost prior to inspection. However, vibration signals are often very complicated due to containing mixture of components transmitted by machine parts. Therefore, it is unlikely to detect any fault by simple visual inspection. Thus, the signal is often characterized using some statistical parameters or features. These features can be compared with pre-defined thresholds to detect machinery faults and for tracking their deterioration. Some commonly used statistical measures found in the literature [26–35] include RMS, mean, SD, variance, skewness, kurtosis, CF, IF, SF and range. Mathematical description of the features can be found in Section 1.1.

The RMS, mean and SD values define the energy of vibration signal, its CT and the dispersion respectively. These parameters are defined with the same units as the vibration signal. The standard ISO 2372 defines three different RMS levels to alarm different machine conditions. The CF, IF, SF, skewness and kurtosis are dimensionless statistics, advantage of which is that they are less sensitive to variations in load and speed [73]. The CF, SF and IF are sensitive to the existence of peaks in the signal. These features are often used to detect faults that involve impacting, i.e. REB, wear, gear tooth wear or cavitation in pumps. Higher-order statistics, such as skewness and kurtosis describe the shape of the signal's amplitude distribution. As the skewness is a measure of asymmetry of the distribution, a machine having Gaussian distribution is considered in good

condition. Kurtosis expresses an aspect of spikiness of the signal and is being used widely for fault diagnosis in rotating machinery.

Orbital analysis, obtained from acquiring orthogonal vibration sensors, are also used to detect rotor problems. J. J. Carbajal-Hernandez et al [74] used orbit analysis method to detect misalignment and unbalance problems in electrical induction motors. After mapping the faults into patterns, a classifier was utilized for recognizing induction motor faults.

2.4.2 Frequency Domain

Potential faults in rotating machinery can be analyzed using FD spectrum, which is based on the transformed signal. The FD analysis is the most common technique for the purpose. The technique is now part of almost every commercial available vibration analysis software. The analysis method is usually performed using the fast Fourier transform (FFT) algorithm [75]. The algorithm is an efficient version of the discrete Fourier transform (DFT). The FFT processing can be described as

$$X(k) = \sum_{n=0}^{N-1} X(n) e^{-j\left(\frac{2\pi}{N}\right)nk}, \quad k = (0, 1, 2, \dots, N-1) \quad (2.7)$$

$$X(n) = \frac{1}{N} \sum_{k=0}^{N-1} X(k) e^{j\left(\frac{2\pi}{N}\right)nk}, \quad n = (0, 1, 2, \dots, N-1) \quad (2.8)$$

Frequency analysis can identify and isolate certain frequency components of interest. Generally, the amplitudes of the fault-related frequencies are compared with some standard values. In case these values are below certain threshold levels, the machine is considered healthy [76–79]. Otherwise, the characteristic rotational frequencies related to specific machinery faults are investigated for further action. Beside comparing the amplitudes of specific frequencies, the amplitudes of particular frequency bands of interest can also be investigated [80]. The fundamental assumption in frequency analysis is that the data to be analyzed is stationary or

can be reduced to stationarity by a simple transformation. If frequency content of a signal vary with time, the Fourier analysis will provide a time-averaged summary. Therefore, it is not an appropriate method for non-linear, non-stationary signals such as sliding in REB, rotating fluctuations or so on.

Other spectra, based on the Fourier transformation, have also been reported for fault diagnosis of rotating machinery [3]. These spectra include power spectrum [2], cepstrum [81], bi-spectrum [82], tri-spectrum [83], and holo-spectrum [84]. Power spectrum defined as the Fourier transform of autocorrelation function of signal, and reflects the energy at some specific frequency. Whereas, the cepstrum can detect harmonics and sideband patterns in power spectrum.

2.4.2.1 Envelope Analysis

Fault frequencies (Equations 2.1 to 2.4) generated by localized faults of REB, already discussed in Section 2.2.1, can be observed by frequency analysis of enveloped vibration signal. Enveloped analysis is also known as high frequency resonance technique (HFRT), and is considered as the benchmark method for bearing diagnostics at early stages. Procedure of envelope analysis involves bandpass filtering of the signal, envelope calculations and finally transformation to frequency domain with FFT, as illustrated by Figure 2.6.

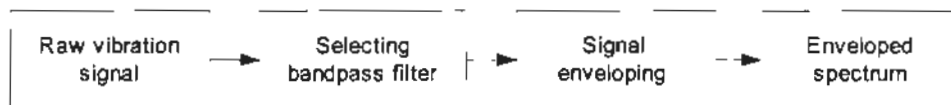

FIGURE 2.6: Envelope analysis procedure

The impulses, generated by REB's localized fault excite resonant frequency of the structure or bearing housing. Consequently, fault frequency components are generated in a high frequency region of the spectrum. This is also described as amplitude-modulation operation where the resonance frequency is carrier signal and the fault generates the modulating signal. The spectrum of the modulated signal will be a peak of the carrier frequency with sidebands of the modulating frequency. However, in noisy vibration signal, it is very difficult to visualize these

sidebands directly in the raw spectrum. By applying enveloping or demodulating technique, the information is transferred at low frequency region. During the process, the bandpass filtering process is crucial, its purpose is to reject the low frequency and high amplitude components in the signal. Low and high frequencies often associated with rotor's misalignment or unbalance and the noise respectively. Squared envelope spectrum is recommended due to exhibit lesser sensitivity to high order harmonics [85]. The squared envelope spectrum also improve the signal to noise ratio in certain situations [86].

In spite the envelope analysis is a powerful technique, the improper selection of the frequency band can render the analysis ineffective [14]. The efficiency of enveloping for REB fault diagnosis depends on the choice of the most impulsive band for demodulation. The most common practice is to determine the characteristics of the band-pass filter in terms of center frequency and bandwidth. Howieson [87] states that the most common choice of bandpass filter is between the 2.5 and 5 kHz spectrum region. Nevertheless there is a debate on the proper method to determine the optimum bandwidth of the filter. Many approaches have been proposed in the literature for optimal selection of frequency band, such as spectral kurtosis based methods, spectral energy based methods, wavelet based methods etc, that are discussed in [15, 17]. Spectral kurtosis (SK) based fast kurtogram method, proposed by Antoni [13, 88], was also utilized in this study for frequency range selection to employ enveloping-based data validation process. Application of hammer test is also proposed in order to identify the resonant frequency of the structure.

2.4.3 Time-Frequency Domain

Previously mentioned FD methods such as Fourier transform assume stationary signals to be analyzed. However, localized faults in REB generally introduce non-stationary signal components [3], which cannot be properly described by ordinary spectral methods. The drawback can be overcome by the use of TFD methods, such as short-time Fourier transform (STFT) [89], wavelet transform (WT) [90],

Wigner-ville distribution (WVD) [91], Hilbert-huang transform (HHT) [92] and Teager-huang transform (THT) [93]. A comprehensive information regarding TFD analysis can be found in the review presented by Feng et al [94]. According to the signal's decomposition paradigms, the WT are classified as the continuous WT [95], the discrete WT [96] and wavelet packet analysis [97].

The TFD methods have wide applications for the fault detection of REB. X. Lou and K. A. Loparo [19] presented a fault classification scheme based on WT and neuro-fuzzy. The WT was used to process vibration signals and to generate feature vectors for adaptive neural-fuzzy inference system (ANFIS). J. Altmann and J. Mathew [22] presented a method to enhance the detection of low-speed REB's faults that was based on discrete WT. To achieve better signal-to-noise ratio (SNR), wavelet packets was performed via an adaptive ANFIS for automatic extraction of fault-related features. An autoregressive (AR) spectrum of the enveloped signal was used in conjunction during the fault detection process. W. Caesarendra et al [18] also dealt very low rotational-speed REB to identify its localized faults. Empirical mode decomposition (EMD) and ensemble empirical mode decomposition (EEMD) were applied. C. Smith et al [20] explored fault detection in aircraft. The characteristic features were extracted from noise using the daubechies, haar and morlet wavelets. Then detection of the vibration signal was achieved via signal's scalogram. D. Yang [98] addressed the fusion of Hilbert transform and bi-spectral analysis to extract features of faults in a number of conditions in induction motor bearing. Wavelets have also been utilized for denoising [21, 23] the vibration signals to enhance the fault detection in REBs.

The TFD methods also contributed to rotor faults detection. Climente-Alarcon et al [99] presented a wideband diagnosis method using WVD to detect eccentricity and high-order components generated by asymmetric rotor. Liu et al [100] proposed a new multiple window S-method based on time-frequency analysis for motor fault diagnosis. Z. Feng et al [94] reviewed various TFD methods including linear and bilinear timefrequency representations applied extensively to machinery fault diagnosis. The systematic study presented over 20 major TFD methods

reported in more than 100 representative articles since 1990. Advantages and disadvantages have been discussed along with their fundamental principals.

2.4.3.1 Spectral Kurtosis

Based on the STFT, the Fourier transformation is applied to many short-time windows. Spectral Kurtosis (SK) determines a portion of signal containing maximum impulsivity using frequency bands. The SK provides the measure of impulsiveness as a function of frequency and has been used to determine the most appropriate band for the envelope analysis [2]. Assuming a signal $x(t)$ and $X(t, f)$ is its complex envelope computed by the STFT, then the SK can be calculated as,

$$K(f) = \frac{\langle |X(t, f)|^4 \rangle}{\langle |X(t, f)|^2 \rangle^2} - 2 \quad (2.9)$$

where $\langle . \rangle$ is the time averaging operator. The following important properties makes SK very effective for the fault diagnosis of bearing [101],

- i) It is zero for a stationary Gaussian process
- ii) It acts as a constant function of frequency for a stationary process
- iii) Its value for non-stationary signal, in the presence of stationary noise, has large values at frequencies where the SNR is high.

Antoni and Randall [102] utilized these concepts to define a representation tool known as kurtogram. The kurtogram determine the optimal filter characteristics to find center frequency (f) and frequency bandwidth (Δf). Antoni [13] introduced an improvement of the method for industrial applications named Fast Kurtogram, which progressively decomposes a vibration signal in bands. The SK is computed for each band then using a FIR filter bank. The filter bank structure decomposes the signal via a dyadic grid extended to a richer 1/3 decomposition with three additional filters offering a finer frequency resolution plane. The optimal filters center

frequency and bandwidth can be used finally to select the appropriate bandpass filter for the envelope analysis.

2.4.3.2 Order Tracking

In non-stationary working conditions like time-varying speed, the order tracking method is applied to transform a vibration signal from time domain to angular or order domain to maintain stationarity [103]. In this way, smearing problem of discrete frequency components, due to rotating speed fluctuations, can be avoided. Three main categories of order tracking techniques are re-sampling method, Kalman filter based method and the transformation based methods [104]. The most commonly used re-sampling method is also employed in this research during data validation process in conjunction with envelope analysis. In this methods, both vibration and tachometer signals are acquired simultaneously at constant time intervals ($[\Delta]$). The acquired samples are re-sampled then using software-based interpolation to obtain new data samples. These new samples lie at constant angular increments with the rotation of shaft ($\Delta\theta$). The re-sampled data can be further processed using traditional FFT analysis, described as follows.

$$X(\Omega) = \int_{-\infty}^{\infty} x(\theta) e^{j\Omega\theta} d\theta \quad (2.10)$$

$$X[k] = \frac{1}{N} \sum_{n=0}^{N-1} (x[N\Delta\theta]) e^{j\Omega[k]n\Delta\theta} \quad (2.11)$$

where $\Delta\theta$ is the resolution in angular domain, N is the number of samples of interpolated signal $x(\theta)$ and $\Omega[k]$ indicates the vector of orders to represent order spectrum.

2.4.4 Phase Analysis

Position of a rotating part captured at any instant with respect to a fixed point is known as phase, which indicates the direction of vibratory motion. Collection of phase measurements taken from various machine locations reveal information regarding relative motion of vibrating parts of machinery. Phase is usually measured using absolute or relative techniques [1]. Absolute phase is measured using single sensor and single tachometer referencing a mark on the rotor. At each measurement point, the analyzer calculates the time between trigger of tachometer and next positive peak of vibration waveform. The calculated time interval is converted to degrees and then displayed as the absolute phase that is also used in rotor balancing application. On the other hand the relative phase is measured with the help of multi-channel analyzer to calculate the cross-channel phase. One single-axis sensor serves as the fixed reference and the other one is moved sequentially to the other required test points. On the other hand, relative phase is the time difference between the waveforms, converted to degrees, at a specific frequency.

A phase should be studied for machines where the source of the vibration is not clear or when it is necessary to confirm suspected sources of vibration, for example soft foot, cocked bearings and bent shafts, confirm unbalance state of rotor, mechanical looseness, bending/twisting and shaft misalignment [105]. Phase is very important tool to detect unbalance fault because 1X harmonic of vibration can also be generated by other machine parts as well. For example, the phase shift from horizontal to vertical should be approximately 90 degrees for rotor unbalance faults.

2.5 Machine Learning based Diagnostics

Many modern approaches to fault identification are based on the emerging field of PR based on AI [106]. Worden et al [107] reviewed the machine learning based fault diagnostic techniques for automatic decision making. Machine learning falls

in two categories; supervised learning and unsupervised learning. The choice of the learning method depends on the availability of data. Supervised learning is feasible where historical information or fault data are available. However, there may be situations in which it is difficult to acquire data in some real systems. In that case unsupervised learning is used. The present research employed supervised learning methods.

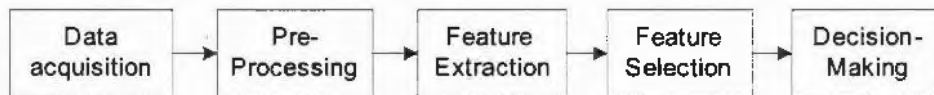

FIGURE 2.7: Pattern recognition process

Figure 2.7 shows the main phases of supervised learning based faults classification process that include data acquisition and its pre-processing, feature extraction, feature selection and decision-making.

2.5.1 Data Acquisition

Measuring appropriate data is the first requirement to develop an intelligent fault diagnostic system. Data acquisition deals with the type of measured data and type of sensors and their placements or mounting locations on machinery. The selection of appropriate sensors and their locations depend upon the type of machine under test, its construction and fault diagnosis application [108]. The sensors and recording equipment used to measure data are discussed in detail in [108, 109]. The measured data can be vibration, acoustics, oil analysis information, pressure, temperature, and environment data etc. Vibration-based diagnostic system consists of accelerometers, velocity transducers, dual vibration probes, laser vibrometers, encoders, tachometers, etc. [110]. Overview of using multiple sensors and data fusion techniques are also covered in [3].

2.5.2 Pre-Processing

The collected data may be polluted by different kind of noises, i.e. sensor response, the measurement noise, quantization noise in adopting digital representation and

the unrelated noise from other sources. Before fault features are extracted, it is often required to clean-up the measured TD data. For the purpose, filtering and removal of outliers are the popular methods [107]. Various approaches exist for noise filtration, such as classical approach like kalman filtering [111], adaptive filtering [112] and WT based methods [113]. However, pre-processing should be performed carefully to avoid loss of any valuable information concerned with the fault diagnosis.

It is usually very difficult to detect their low amplitudes in acquired vibration signals, especially in REB's case. The signals usually contains vibration components produced by other joint machine parts. For example, in rotor-bearing system, the rotor often produce some amount of unbalance or misalignment producing larger amplitudes comparing to REB's faults. Therefore, the spectra of raw vibration signals contain very little diagnostic information regarding the these faults [2]. To facilitate the fault detection process, most of the existing fault diagnosis methods involve certain pre-processing of raw data. Apart from noise reduction, the pre-processing normally includes the extraction of an appropriate frequency range before further analysis. In this regard, enveloping [12–17] and empirical mode & wavelets decompositions [18–23] are the most frequently used techniques.

2.5.2.1 Outlier Detection

Outliers are the values in data pattern that do not adapt an expected behavior, and outlier detection (OD) methods have been used in a wide variety of applications such as military surveillance, fraud detection for credit cards, intrusion detection in cyber security, insurance and fault detection in critical systems [114]. The OD is also a well studied area of data mining, and has been classified mainly into statistical approaches, depth-based approaches, deviation-based approaches, distance-based approaches, density-based approaches and high-dimensional approaches [115]. A number of surveys, review articles and books cover these approaches in machine learning and statistical domains [116–121]. Data mining generally utilizes a collection of data instances, i.e. pattern, object, record, point,

vector, event, case, sample, observation, entity etc [122]. Each data instance is described using a set of features or attributes, which can be of different types such as binary, categorical, or continuous. The nature of attributes also determines the applicability of the OD methods [122], as the selection of right detection method is vital according to the nature of application and normal behavior of the specific phenomena [114]. This research utilizes the Box plot [123] for OD of features values because of offering functional simplicity and situation.

2.5.3 Feature Extraction

After acquiring and pre-processing, the fault features can be extracted using signal processing techniques already covered in Section 2.4. The techniques allow the extraction of various kind of diagnostic features for the PR process. This section contains an overview of the most important feature extraction methods for PR-based diagnostics. Statistical values can be extracted using TD data, amplitudes of specific frequencies from FD, and decomposition results (e.g. wavelet coefficients) from TFD. The TD feature extraction methods are considered among the first diagnostic tool because of utilizing time waveform directly. Some simple statistical measures like RMS, mean, SD, variance, skewness, kurtosis, CF, IF, SF, range etc can be used to compare and identify the state of a machine. The FD methods are certainly among the most common feature extraction techniques for bearing fault detection due to its ability in identifying and isolating certain frequency components of interest. The methods rely on the detection of the characteristic rotational frequencies related to specific machinery faults. These frequencies could be noticed by observing the envelope of the vibration signal acquired for a damaged bearing. They are FTF, BPFO, BPFI, BSF, described already in Section 2.2.1. Most of the traditional signal processing methods can only be applied to stationary signals and cannot reveal the local features in both time and frequency domains simultaneously. The TFD techniques are then powerful methods to identify the health information. Time variant features and the frequency components from acquired non-stationary signals can be extracted as fault features. Yang et al [124] reviewed

those available in the relevant literature. B. Samanta and K. Al-Balushi [29] presented a procedure for fault diagnosis of REBs through ANN. The characteristic TD features were used as inputs to the ANN with normal and defective bearings, consisting of input, hidden and output layers. The TD features were obtained from direct processing of the vibration signal segments. The effects of some preprocessing techniques were studied prior to feature extraction like high-pass filtration, band-pass filtration, enveloping and wavelet transform of the vibration signals. B. S. Yang et al [30] presented a new neural network (NN) for fault diagnosis of rotating machinery. The technique synthesizes the adaptive resonance theory (ART) and the learning strategy of kohonen neural network. In order to test the proposed network, the vibration signal were processed as inputs. The results of the experiments were compared with other NNs. L. Zhang et al [31] utilized genetic programming (GP) to detect rotating machinery faults. Feature sets from two different machines were used to determine the performance of bi-class recognition. The results are compared with a few other methods for fault detection. The GP have been used for feature selection for ANNs and SVMs. The proposed method demonstrated better performance than that of the previous approaches on these data sets. The training times are also found to be considerably shorter and the generated classification rules were easy to understand. V. Sugumaran and K. Ramachandran [32] presented a method to form a rule set from the TD features for fuzzy classifier. Decision tree was employed to generate the rules automatically from the extracted features. The features discriminated the different fault conditions in REB. P. Kankar [33] utilized ANN and SVM to study faults in REB. Statistical methods were used to extract features and to reduce the dimensionality of original vibration features. The study examined that the machine learning algorithms can be used effectively for automated diagnostics of REB. V. Sugumaran and K. I. Ramachandran [34] examined that often the researchers overlook the issue of choosing the number of features for optimum performance of a classifier. The SVM and PSVM classifiers were fed statistical and histogram features extracted from vibration signals for REB's fault diagnosis. M. Saimurugan et al [35] emphasized that majority of machine problems were generated from faulty

bearings that consequently affect the rotor. They employed c-SVC and nu-SVC models of SVM with four kernel functions for fault classification. Decision tree algorithm was used to select the salient TD features to diagnose multiple faults in rotor and REB.

The literature survey reveals that a little work has been carried out regarding the accurate extraction of diagnostic features for rotating machinery fault diagnosis. Lee et al [24] examined the sensitivity of diagnostic features for prognostic and health management (PHM) system, with respect to the signal quality and failure modes/ operating conditions of the system like speed, load, or torque. The presented methods utilized several features from time and frequency domains to develop algorithms to identify various faults in bearing, gear and shaft [25]. The frequency domain features included the fault frequencies exhibited by the rotating components. The traditional TD statistical features, i.e. RMS, kurtosis, crest factor etc. were also examined for fault detection and prognosis. The authors emphasized that it is critical to reduce signal noises and eliminate outliers before extracting diagnostic features to obtain accurate results and prevent the system from high false alarm rates. Widely implemented existing outlier detection methods, such as distance based [126], density-based spatial clustering of applications with noise [127], and minimum covariance determinant [128], were employed to identify the data points to be discarded. While focusing on the front end of a PHM system, the authors suggested following steps for reliable outcome from the system; 1) outlier detection to remove abnormal data from raw vibration signal, 2) pre-processing of the vibration signal to reduce unwanted noises, 3) cluster based operational mode detection method to group various operating conditions, and 4) neural network training based feature normalization to mitigate the effects of operating conditions on the features.

Difficulty with the above mentioned method was the complexity and computational cost, especially employing TD features. Recently, M. M. Tahir et al [129] presented a vibration-based feature processing method, which was employed prior to use classifier in PR model. The CT-based method was applied to identify localized faults in REB using several TD features. The authors discussed that the

random nature of vibration signals can contain fluctuations, which might not be related to the faults under investigation but can affect the statistical values of the features. It was investigated that the affected features might not be able to represent the true fault conditions, and mislead the classifier rather. During feature-level processing, the presented method put every feature distribution under test separately to check whether the feature contained one or more outlier values. In case any feature distribution contained any outlier, the whole instance was discarded from the training data-set. The strategy was analogous to discarding the specified vibration sample from which the TD features were extracted and isolating the unrelated machine components from the problem at hand. The method adequately mitigated the effect of undesired fluctuations on the PR-model and improved its diagnostic capability. In addition to efficiency, the method also offered significant immunity to background noises. The authors emphasized to employ accurate TD features for trustworthy recognition of bearing's fault patterns instead of using raw features.

2.5.4 Feature Selection

The stage of selecting salient features is of great importance because the feature extraction process often generates a large quantity of features. These features may have marginal importance for classification or even they can reduce the classifier's performance. The performance of a diagnostic model also relies on the number of features and the dimensionality of the feature vector v . Increasing the size of the feature vector may not necessarily provide additional information to the model. Thus, dimension reduction is desired for efficient decision-making. Guyon [130] gave an introductory treatment about this subject in the field of machine Learning.

There exist two ways to perform dimension reduction. One is known as transformation-based reduction, which involves an irreversible transformation. Principal component analysis (PCA), project pursuit (PP) [131], Isomap [132] are commonly used algorithms for the purpose. For instance, the PCA chooses the first few valuable components and discards the rest of unimportant principal components. The

continuous data type, the problem is called regression. If the label is discrete, the problem is divided into further two categories, i.e. for nominal variable label, the problem is called classification and in case of an ordinal variable, the problem is known as ordinal ranking [135].

There exist several supervised learning based classification methods, which have been used for fault classification in rotating machinery. These methods mainly include Bayesian classification methods, nearest-neighbor search, ANNs, SVMs, decision tables, decision trees, fuzzy systems and hybrid systems. There is a trade-off between the resolution of the diagnosis and the noise rejection capabilities of the algorithms. Even if the cleaned data has little noise in the measurement from normal operating condition, small damages will cause detectable deviations [108]. Thus, eliminating noises is necessary for intelligent fault detection. Most of the above mentioned learning methods are already covered in the previous sections to identify faults in bearing and rotor. Bearing fault diagnosis has been carried out using Bayesian networks [136], nearest-neighbors [137, 138], ANNs [139], SVMs [140–142], decision tables [129], decision trees [34, 35], fuzzy systems [143] and hybrid systems [144–146]. The PR has also been a popular domain for automatic diagnosis of rotor faults. The methods include artificial neural networks [147], Bayesian networks [148], SVM [8, 149], entropy & optimization methods [150] and fuzzy logic [151]. Main objective of the present research is to enhance the reliability of TD features extracted from vibration signals for PR-based faults classification models. New methods are presented to obtain accurate and fault-related features to the classifier for trustworthy decision making. To evaluate the performance of the proposed methodologies and their effect on classification models, SVM [38], bayesNet [39], decision table [40] and decision tree [41] are utilized. These classifiers are explained in the next chapter.

As mentioned above, the supervised learning paradigm requires a data-set with labeled patterns to train a classifier. Once the classifier is trained, it is then employed to test the unknown examples. Figure 2.9 illustrates the supervised learning based PR process.

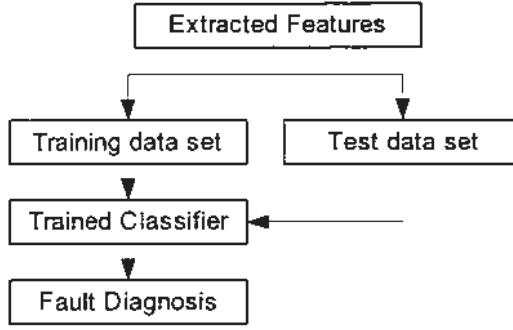

FIGURE 2.9: Supervised learning based pattern recognition

The performance estimation method $K - fold$ cross validation is mostly used for training and testing of all the classifiers. The method splits the data D into k equal parts, i.e. D_1, \dots, D_k . A single part is retained as the validation data to test the model, and the remaining $k - 1$ parts are used as training data. The process is repeated k times, with each of the k parts used exactly once as the validation data. The k results obtained from the folds are then averaged out to produce a global accuracy or single estimation.

$$Accuracy_{global} = \frac{1}{k} \sum_{j=1}^k Accuracy_j \quad (2.12)$$

The advantage of cross validation method is that all examples are involved for both training and validation.

The formulated research hypotheses, in Chapter 1, may not be addressed properly using conventional fault diagnosis methods like TD, FD or TFD methods. The reason is very weak vibrations produced by the bearing faults that can also be influenced by the other joint machine parts. Moreover, the vibration signals usually have to be propagated through complex machine structures [3]. The rotor faults, mentioned in the research problem, are not simple to be distinguished using the conventional methods. Therefore, this research utilizes the emerging field of PR for trustworthy diagnostics of these critical faults.

2.6 Summary

This chapter covers a wide range of literature regarding rotating machinery, occurrence of common faults, fault diagnosis methods and vibration-based fault diagnostic techniques [2, 7]. The chapter starts from CM technologies, which cover different disciplines including vibration analysis [1]. Focus of the chapter is vibration-based fault diagnosis of the machinery faults using supervised learning based PR methods [10]. Diagnosis of the localized faults in REB [5, 6] and unbalance [49, 50] and misalignment [51] faults in rotor are discussed in detail.

The literature reveals that the PR methods are effective but noise in the signals can mislead the statistical classifiers [11]. The TD features can be very useful but need to be extracted carefully for best results, otherwise inaccurate feature values may influence the supervised learning process. Major contributions for REB fault diagnosis using TD features include [26–35, 129]. Section 2.5.3 covers most of the pre-processing methods, which have been applied to clean up the vibration signals for better results. In this regard, enveloping [12–17] and empirical mode & wavelets decompositions [18–23] are the most frequently used techniques. In case of rotor fault diagnosis, confirming the unbalance state of rotor is crucial prior to take any corrective action due to criticality of maintenance techniques [37]. Misjudging misalignment with unbalance fault can even aggravate the situation. The TD features have also been employed to recognize the fault patterns of rotor [8, 32, 35]. The present research emphasis on the extraction of accurate TD features to enhance the fault classification accuracy of the faults.

The literature survey shows very little effort has been made to obtain accurate TD features from vibration signals with the intent to fault diagnosis of rotating machinery. The main contributions include [24, 25, 126–128]. The present research also takes into account the outlying values of the extracted TD to achieve the goal. A number of surveys, review articles and books cover these approaches in machine learning and statistical domains [116–121]. This research utilizes the Box plot [123] for the detection of these outliers for obtaining the accurate features. Several classifiers are utilized to evaluate the performance of the proposed

methodologies and their effect on the fault classification accuracy. Section 2.5.5 covers the classifiers, which include SVM [38], bayesNet [39], decision table [40] and decision tree [41].

Chapter 3

Enhancing Fault Classification Accuracy of Ball Bearing using Central Tendency based Time Domain Features

Presence of fluctuations or spikes in random vibration signals can considerably affect consequently the statistical values of the extracted features. This chapter discusses the sensitivity of TD features against these unrelated fluctuations while classifying localized faults in REB. Based on the sensitivity level, the features are statistically processed prior to employing classifier in PR-model. A CT based feature processing method (CTBFP) [129] is developed and employed prior to use classifier in vibration based PR model to classify ball bearing's localized faults. Idea is to disassociate the effect of undesired fluctuations on the sensitive TD features before supervised learning and fault classification. The adequately processed features are found robust and provide higher diagnostic information to the models. Major contributions of this research include:

- The CTBFP method is developed and employed prior to use classifier in vibration based PR model to classify ball bearing's localized faults.

- The presented method ensures the provision of only appropriate features values to the classifier, and enhances the fault classification accuracy.
- In addition to computationally efficient, the method is immune to possible fluctuations present in steady state vibration signals.

The chapter is organized as follows. Section 3.1 Section 3.3 elaborates the major steps involved in the proposed diagnostic scheme. Section 3.4 discusses the results achieved and findings of the proposed research, whereas the study is summarized in Section 3.5.

3.1 Pre-Processing

In the last chapter, Section 2.4 already covers basic techniques of pre-processing, which normally includes noise reduction and extraction of appropriate frequency range. As the identification of REB's localized faults is normally very difficult due to producing very low amplitudes in vibration signals. Thus, most of the existing fault diagnosis methods involve certain pre-processing of raw vibration data. Section 2.5 already discusses numerous vibration-based machine learning PR methods, the performance of which may be effected by the presence of background noise. Several methods have so far been employed to detect the bearing faults using TD statistical features. Maintaining an optimum classification accuracy, however, using a minimal set of features has been a challenge for the researchers, in spite of applying certain costly pre-processing methods.

Instead of pre-processing the raw vibration data, this research proposes statistical processing of features prior to employing classifier in PR-model. Besides efficiency, the pre-processed features considerably enhance the diagnostic capability of a classifier. The TD features utilized are RMS, mean, variance, skewness, kurtosis, CF, IF, SF, median and range. The feature processing technique is based on the detection of outliers during data preparation stage of supervised learning [10]. The purpose is to supply only the appropriate features to classifier for better

decision making. A substantial advantage of the proposed pre-processing of TD features over conventional pre-processing of raw data is the computational cost. Because few values in a feature distribution are required to be processed rather than processing the huge vibration signals to aid the diagnostic process.

The literature survey (Section 2.4) shows very little work has been carried out so far regarding the accurate extraction of diagnostic features for the fault diagnosis of rotating machinery. The literature suggests that it is very crucial to reduce signal noises and eliminate outliers before extracting diagnostic features to obtain accurate results. The presented methods utilized several features from TD, FD and TFD to develop algorithms to identify various faults in bearing. Difficulty with the existing methods is their complexity and computational cost, especially employing the TD features. Reliability of the TD features may be improved by simpler means rather, particularly for PR-based diagnostic models. The random nature of vibration signals can contain fluctuations, which may occur due to even change in dynamic operating conditions. The variations in acquired vibration signals consequently produce outlying values in the extracted features. Physical causes or mechanical phenomena behind the occurrence of signal fluctuations are not discussed in this study. However, an important and valid assumption was made here that the particular phenomena should not be associated with the faults under investigation, i.e. bearing faults in our case. This particular situation allows processing of TD features directly instead of pre-processing the huge set of raw vibration data. A feature processing method has been developed that is based on CT of the features distributions. The method deals with the possible outliers adequately while preparing data before incorporating classifier in a PR model. Several classifiers including SVM, bayesNet, decision table, and decision tree are used to evaluate the proposed method. All the classifiers are found better decision makers while utilizing processed features. The feature pre-processing method works in two distinct steps; 1) detection of outliers present in the features distributions, and 2) discarding the affected instances or examples before introducing classifier in the model. This study utilizes the median score in any feature distribution as its CT measure, as the median effectively isolated the outliers generated due to

the fluctuations in vibration signals. Median-based commonly used outlier detection methods include Box plot and median absolute variance (MAD). The Box plot [123] is employed because of offering functional simplicity and suitability to our application.

3.2 Experimental Setup

The data set from CU [152] has been used to evaluate the performance of the proposed method. Radial vibration measurements are taken using a MFS. An accelerometer is mounted on the top of outboard bearing housing to acquire data for IR and OR bearing faults. Ball bearings model MB ER-16K are used to rotate healthy shaft containing a loader in the middle, as shown in schematic of the setup in Figure 3.1. The bearing model contains 9 balls ($N_b=9$) having diameter (B_d) 7.94 mm, whereas the pitch diameter (P_d) is 38.50 mm and contact angle (β) is zero degree. Motor speed was 29 Hz measured using tachometer. Vibration signals along with their respective speed signals are captured at the sampling rate of 51200 samples/sec. For more details, the reader is referred to [152].

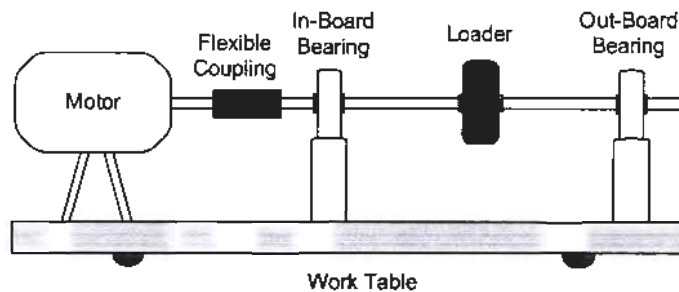
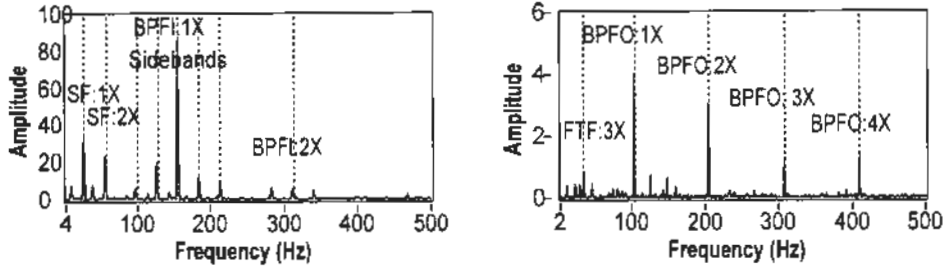

FIGURE 3.1: Schematic of experimental setup

3.2.1 Data Validation

Envelope analysis has been used as benchmark method for bearing's fault diagnosis over the years [2]. We have employed spectral kurtosis based fast kurtogram method proposed by Antoni [13, 88] for frequency range selection in terms of



(a) Enveloped spectrum of bearing's IR fault (b) Enveloped spectrum of bearing's OR fault

FIGURE 3.2: Enveloped spectra of the bearing faults

center frequency and bandwidth. Section 2.4.2.1 already explained the enveloping method, which was implemented for IR and OR vibration signals using NI LabVIEW. Order analysis based function *OAT Envelope Detection (Even Angle Output)* was employed prior to obtain power spectra of the envelope signals (Section 2.4.2.1). The function utilizes a frequency band and tachometer signal for extracting even-angle envelope signal. The angle-domain output signal maintains constant number of samples per revolution to mitigate the effect of speed variations. Table 3.1 shows BPF:1 and BPF:2 frequencies representing IR and OR faults, calculated using Equations 2.1 to 2.3. The calculated center frequencies and bandwidths of IR and OR faults are also shown in the table respectively, i.e. CF_{IR} & BW_{IR} , and CF_{OR} & BW_{OR} .

TABLE 3.1: Bearing fault frequencies along with the central frequencies and bandwidths (Hz)

SF	FTF	BPF:1	BPF:2	CF_{IR}	BW_{IR}	CF_{OR}	BW_{OR}
29	11.5	157.4	103.6	24533	2133	9066	1066

Figure 3.2(a) provides the enveloped spectrum of bearing's IR fault, in which the BPF:1 is visible along with the side-bands of shaft's speed. Figure 3.2(b) shows the several harmonics of the BPF:2 to represent OR fault. Thus, the data-set used in the present study contains every required information for data validation.

3.3 Materials and Methodology

The proposed fault diagnostic scheme consists of four steps, which are elaborated in the block diagram in Figure 3.3. Details of the proposed methodology are in the following subsections.

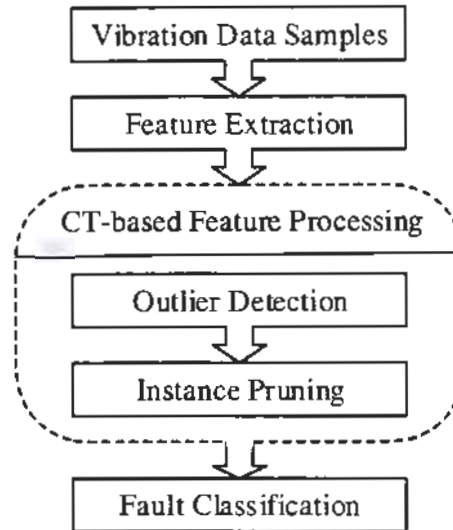

FIGURE 3.3: Block diagram of CTBFP-based fault diagnosis of ball bearing

3.3.1 Vibration Data Samples and Feature Extraction

At first step, vibration signals were segmented to obtain data samples, and features were extracted from these samples to form data set at second step. Every signal of 10 seconds duration was divided into 40 segments. As the motor speed was 29 Hz, each segment holds vibratory history of more than 7 revolutions of the shaft. In this way, the segments contained a valid sample length to compute trustworthy statistical features. Above mentioned ten feature were extracted from every data segment of each fault to form the data-set for the supervised learning and fault classification. The features are described mathematically in Section 1.1.

3.3.2 CT-based Feature Processing (CTBFP)

The third step implements the feature processing mechanism, which is the central theme of the proposed research. The feature processing ensures the use of most

appropriate data by the classifiers. The CTBFP works in two phases; firstly the Box Plot outlier detection method was utilized to implement the Median-based Outlier Detection (MOD) procedure, and then the instances were pruned based on the outcome of MOD. Details are in the following subsections.

3.3.2.1 Outlier Detection

The CT measure describes a set of data values with a single value. The measures such as mean, median and mode are used usually to describe the CT of the data set [153]. Each measure can be more significant and advantageous under specific conditions. Mean is an effective measure when data distribution remains symmetric. It is susceptible to outlying values and skewed data due to taking into account every element of a data set for its calculation. Median score, on the other hand, occupies the middle position in an ordered set of data and thus less sensitive to the outliers [153]. Usually, more than half elements in a vibration sample belong to normal distribution, and accordingly outliers in the extracted features should lie above the median score when sorted in an ascending order.

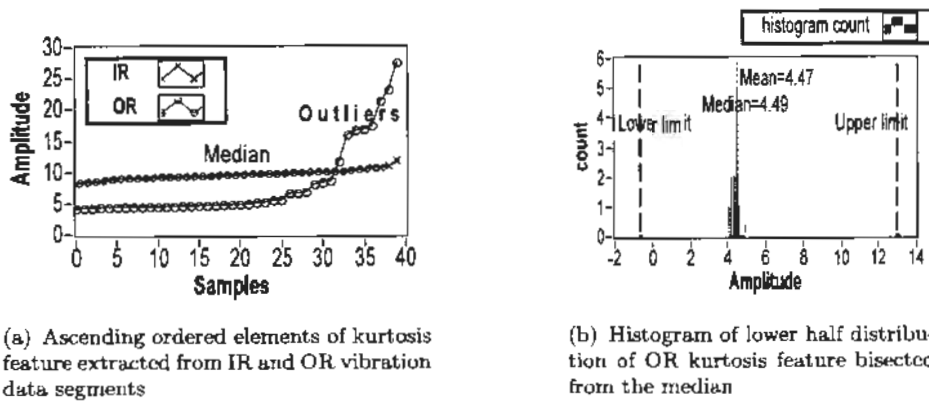

FIGURE 3.4: Median as central tendency measure

Figure 3.4(a) shows the ascending ordered kurtosis feature, where median values of IR and OR distributions are almost insensitive to the outliers. Figure 3.4(b) shows histogram of lower half distribution of OR kurtosis feature, i.e. the part of distribution below its median score. The histogram shows that the lower half

The above relation represents the probability of node X given evidence Y . The posterior probability of node X is $P(X|Y)$, which can be computed using known likelihood $P(Y|X)$ and prior probability $P(X)$. The term $P(Y)$ denotes a normalizing factor.

Fault diagnosis, in a qualitative sense, can be seen as the cause-effect or fault-symptom relations. Every fault and symptom is modeled by a random variable in the network with a probability distribution. Taking the observed symptoms or evidences as input to the network, probabilities of every fault are computed accordingly to the Bayes rule.

3.3.3.3 Decision Table

Decision tables are used to model complex rule sets comprising conditions and actions in a compact way. A decision table is formulated to have four quadrants as shown in Table 3.3. The quadrants on the left describe the conditions as well as the actions being modeled in the table, while the right hand quadrants show the corresponding condition alternatives and action entries. The columns in the right quadrants are called rules. Thus each column has two portions; some of its values are in the condition portion, called inputs, while others are in the action area, termed as outputs. A rule, hence, associates a set of input conditions to a corresponding set of output actions.

TABLE 3.3: Layout of decision table

Conditions	Condition combinations
Actions	Action Entries

Decision tables can be represented in a number of ways according to data being modeled. One way of exploiting decision tables is to model cause-effect relationship by replacing conditions with causes and actions with faults. An example of such an application is machine diagnostics where, on the basis of prior knowledge (rules) connecting observed symptoms to faults, an unknown fault can be classified into known faults.

3.3.3.4 Decision Tree

The classification algorithm producing decision tree is based on information theory. Construction of the tree is based on the learning data set, that is mentioned below;

- Leaf nodes or answer nodes contains the name of fault class
- Decision nodes or non-leaf nodes specifies some test to be carried out on a single attribute or feature value. A decision node contains one branch and sub-tree against each possible outcome of the test.

Criteria to select the root of tree is based on information gain. The measure is used to select among the candidate features at each step of the tree growth. Information gain (S, A) of a feature A relative to a collection of examples S is defined as;

$$Gain(S, A) = Entropy(S) - \sum_{v \in Value(A)} \frac{|S_v|}{|S|} Entropy(S_v) \quad (3.5)$$

where $Value(A)$ is the set of all the possible values for attribute A and S_v are the subset of S for which feature A has value v .

The information gain is the expected reduction in entropy, which measures homogeneity in a set of examples. The gain measures how well a given feature separates the training examples according to the target classification.

3.4 Results and Discussion

Vibration data from CU was found appropriate to validate the proposed feature processing based fault diagnosis scheme. Figure 3.9(a) and Figure 3.9(b) show the time domain signals of IR and OR bearing faults respectively. The OR signal, containing fluctuations, has been cut into two segments Seg_{AB} and Seg_{BC} as marked in Figure 3.9(b). The envelope analysis of both the segments was performed using

CF_{OR} and BW_{OR} in Table 3.1. The Seg_{AB} does not contain any fluctuations and the spectrum of its enveloped signal testifies the OR fault frequencies (BPFO) clearly, as shown in Figure 3.10(a). The enveloped spectrum is quite similar to that of full OR signal already shown in Figure 3.2(b). On the other hand, the Seg_{BC} of OR fault contains some fluctuations, and its enveloped spectrum shows some extra frequencies regarding the bearing cage (FTF) in Figure 3.10(b).

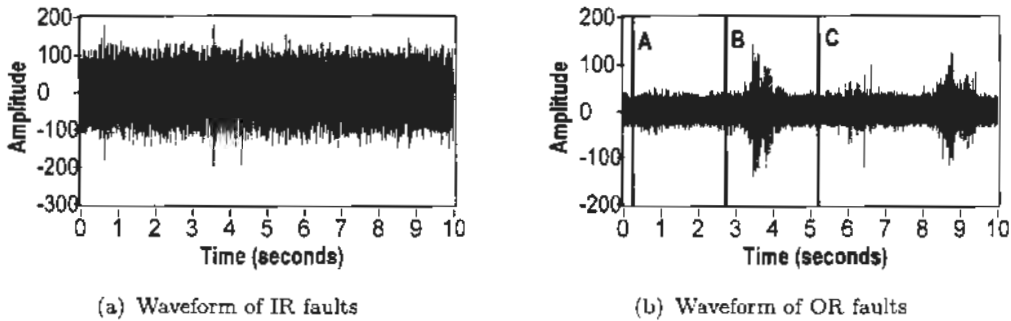

FIGURE 3.9: Waveforms of IR and OR faults

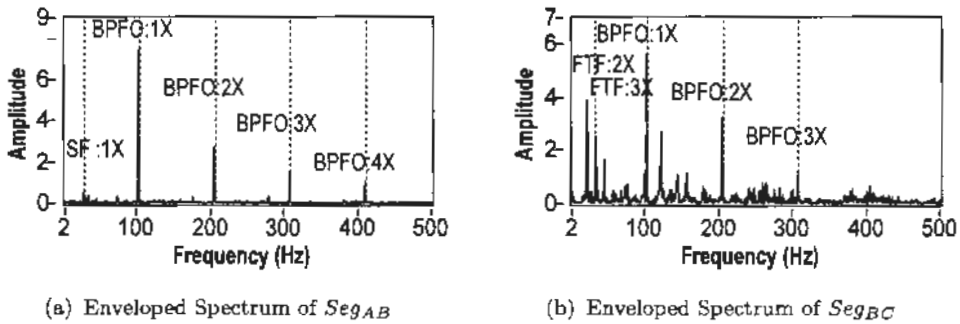
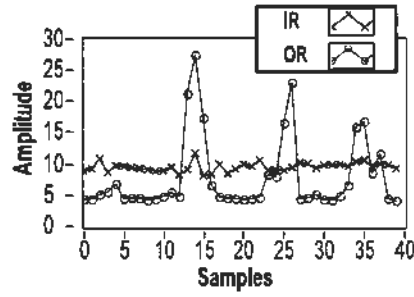

FIGURE 3.10: Enveloped Spectra of the segments Seg_{AB} and Seg_{BC} of OR waveform

The discussion about the phenomena is out of scope for the present research. It is worth mentioning that the features extracted from OR signal generated outliers due to the fluctuations in Seg_{BC} , which significantly reduced the classification accuracy of the classifier. Nevertheless, the phenomenon exhibited in the Seg_{BC} is undesired to study OR bearing fault.

Outliers in a feature, extracted from different faulty signals, can cause overlapping of elements from those fault classes. This may reduce the diagnostic capability of that particular feature, and is a factor of misleading the classifiers. The MOD



(a) Distribution of raw values of Kurtosis feature

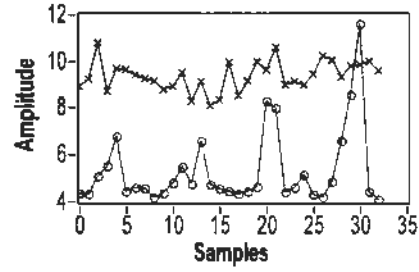

(b) Kurtosis values after discarding outliers

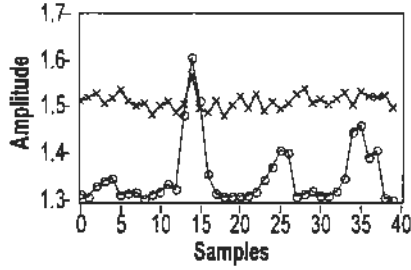

(c) Distribution of raw values of Shape Factor feature

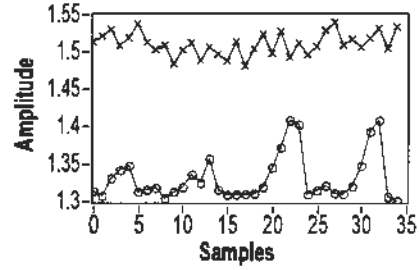

(d) Shape Factor values after discarding outliers

FIGURE 3.11: Feature processing via MOD

adequately handled the issue and ensured the usage of only smoother distributions of the features in diagnostic process.

Figure 3.11(a) shows the raw elements of kurtosis feature extracted from IR and OR faulty signals, which are overlapping repeatedly with each other mainly due to the outliers in OR feature. These outliers were detected by the MOD, and the respective instances were discarded later by the proposed scheme.

The value of 1.5 for *scale* parameter, suggested by [123], was good enough for the problem as almost all the detected outliers belonged only to the fluctuated parts of OR signal. Figure 3.11(b) shows the kurtosis elements of IR and OR fault classes after discarding the outliers. The figure elaborates smoother distributions of the feature against both the faults. Similarly, Figure 3.11(c) and Figure 3.11(d) show the SF feature before processing (BP) and after processing (AP) by the MOD, respectively. Box Plot outlier detection process is shown in Figure 3.12(a) and Figure 3.12(b) for kurtosis and SF features respectively. In this way, every feature was processed separately to mark the outliers in their respective distributions.

TABLE 3.4: Individual accuracies of the features before and after processing, using SVM, BayesNet, Decision Table and Decision Tree classifiers

Feature	SVM		BayesNet		D. Table		D. Tree	
	BP	AP	BP	AP	BP	AP	BP	AP
RMS	99.2	100	100	100	100	100	100	100
Mean	64.4	64.4	72.7	72.7	72.2	72.2	73.0	73.0
Variance	100	100	100	100	100	100	100	100
Skewness	83.7	85.2	86.4	87.1	88.3	89.8	94.3	95.1
Kurtosis	93.2	99.2	93.9	100	95.5	100	95.5	100
CF	86.2	86.4	86.1	86.4	88.1	88.3	87.1	87.1
IF	87.1	87.4	88.3	88.3	90.2	90.5	90.5	90.2
SF	93.9	100	95.5	100	95.5	100	95.5	100
Median	79.7	79.9	84.0	84.3	84.0	84.3	84.0	84.0
Range	90.2	100	93.9	100	93.9	100	93.9	100

During the data preparation process, for the training and testing of the classifier, only those instances were selected which are free from outliers.

Diagnostic capability of the classifiers was observed against every feature individually. Table 3.4 elaborates the impact of proposed method on every feature's fault identification ability, using SVM, bayesNet, decision table and decision tree classifiers. Several features improved their performances significantly in terms of

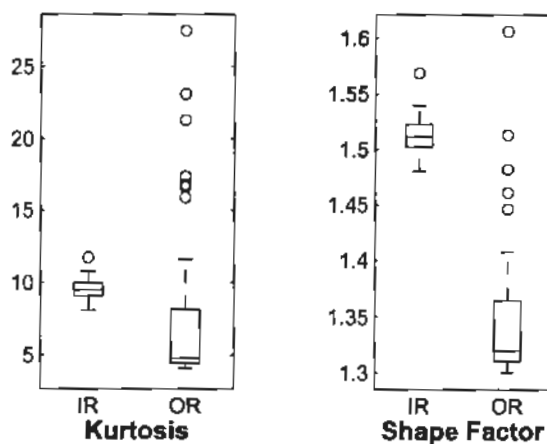

(a) Box Plot applied on kurtosis features from IR and OR faults

(b) Box Plot applied on Shape Factor features from IR and OR faults

FIGURE 3.12: Outlier detection via Box Plot

has been observed that undesired fluctuations occurring randomly in vibration signals produce outliers in the extracted TD features, which mislead the classifiers in their supervised learning process. It has also been noticed that the occurrence of these fluctuations have not been associated with the bearing's fault under investigation. On the basis of the above observations, this chapter presented a new CTBFP method to detect the outliers adequately by implementing the MOD, and the affected instances have been pruned at the next stage based on the MOD outcome. In this way, the presented technique assures the employment of only relevant and precise features in the diagnostic models. The SVM, bayesNet, decision table, and decision tree classifiers were used to evaluate the proposed method, and the classifiers were found better decision makers when processed features were utilized. Several features, kurtosis, shape factor and range, considerably improved their individual diagnostic capability as per their sensitivity levels to the signal fluctuations and separation ability. Due to feature-level processing in PR-model, the CTBFP method is computational efficient, and may be used for real time fault diagnosis of REB.

Chapter 4

Extracting Accurate Time Domain Features from Vibration Signals for Reliable Classification of Ball Bearing Faults

Application of the CTBFP method, discussed earlier in Chapter 3, may become somewhat limited when available training data-set is small. This chapter presents a new CT-based feature extraction approach, named as CTBFE method [154], for fault diagnosis of REB's localized faults. However, unlike processing the feature distributions, the CTBFE works at feature-extraction-level to obtain reliable TD feature values. The CTBFE method not only preserves number of instances but also provides more accurate results compared to that of CTBFP method. Same TD features and classifiers were utilized in the present study that were used for CTBFP method. Major contributions of this research include:

- New CTBFE method is developed that improves PR capability of classifiers for REB's localized faults.
- The method utilize fault related appropriate portion of a vibration signal for TD feature extraction.

- The CTBFE is computationally efficient and immune to possible fluctuations and noises present in random vibration signals.

The chapter is organized as follows. Section 4.2.2 introduces the CTBFE technique. Major steps involved in the development of CTBFE method are elaborated in Section 4.2 along with its application. Section 4.3 discusses the results obtained and findings of the proposed study, whereas it is summarized in Section 4.4.

4.1 CTBFE Technique

The CTBFE examines the sensitivity of TD features to signal's unrelated fluctuations. Unlike CTBFP, which process the feature distributions during the data preparation stage of supervised learning, the CTBFE method applied at feature-extraction-level. The method dynamically selects the most appropriate portion of vibration signal for the extraction of most accurate feature values, ensuring the supply of very accurate feature values to a classifier for truthful decision making. Features extracted through CTBFE procedure considerably enhances the fault classification capability of the classifiers. The CTBFE method outperforms the previously presented CTBFP method, which may have limitations due to strategy of discarding the affected instances. The presented method is efficient and provides significant immunity to possible fluctuations and background noises present in vibration signals. Vibration data is acquired from different REBs containing localized faults using a test rig to validate the performance of the CTBFE method.

4.2 Proposed Methodology

The proposed fault diagnostic scheme works mainly in three steps, elaborated by the block diagram in Figure 4.1. Details of each step are in the following subsections.

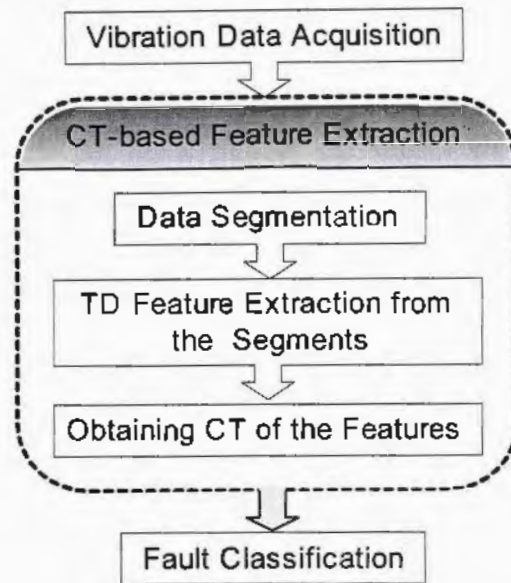

FIGURE 4.1: Block diagram of CTBFE-based fault diagnosis of ball bearing

4.2.1 Vibration Data Acquisition

Vibration data from faulty bearings was acquired using a MFS from SpectraQuest Inc. A set of ball bearings MB ER-12K model was utilized containing different localized faults. The bearing contains 8 balls of diameter 7.94 mm, having pitch diameter 33.50 mm and contact angle of zero degree. The faults include IR fault, OR fault, BL fault and MX fault. The generated fault size measured as 1.5 mm wide and 0.3 mm deep. Figure 4.2 shows the schematic of experimental setup, in which healthy bearing is installed at in-board and the faulty bearing is installed at out-board. A mass of 5kg was placed in the middle of healthy shaft acting as loader. An ICP industrial accelerometer model 608A11 was stud-mounted at the top of out-board bearing housing to measure radial vibration from bearing under test. Sensitivity of the accelerometer was 100mv/g, having operating frequency range 0.5 Hz to 10 KHz and resonance frequency 22 KHz. NI LabVIEW software was utilized along with NI hardware PCI-4472 to acquire data at the rate of 60K samples/sec at motor speed of 1000 RPM. Forty vibration samples have been acquired for each fault, and each sample contains vibratory history of 10 seconds.

To validate the acquired data set, envelope analysis has been implemented again using fast kurtogram method [88]. Table 4.1 shows fault frequencies calculated

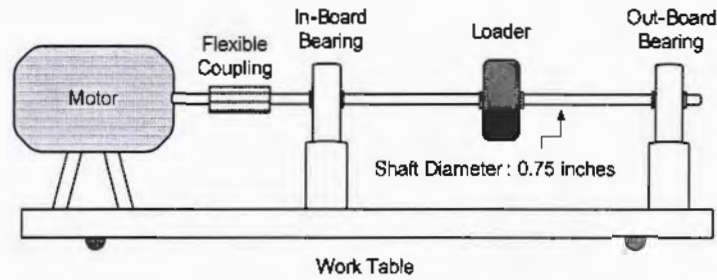

FIGURE 4.2: Schematic of experimental setup

using Equations 2.1 to 2.4.

TABLE 4.1: Fault frequencies of bearing

Motor Speed	FTF	BPFI	BPFO	BSF
16.7	6.4	82.5	50.9	33.2

The enveloped spectrum of IR fault is shown in Figure 4.3(a). Harmonics of the BPFI are present in the spectrum along with the side-bands of shaft's speed. Figure 4.3(b) elaborates the first harmonic of the BPFO representing bearing's OR fault. The BL fault is evident in Figure 4.3(c), where twice the BSF is present along with the FTF. Figure 4.3(d) shows the enveloped spectrum of MX fault of the bearing, in which the BPFO and the BSF are dominating. Figure 4.3(c) and Figure 4.3(d) demonstrated no noteworthy frequency patterns above the 250 Hz, and thus the maximum limit of the graphs is set to 250 Hz to zoom-in the valuable part of the graphs. Hence, all the required information related to ball bearing localized faults are present in the data set.

4.2.2 CT-based Feature Extraction (CTBFE)

The second step is the core of diagnostic scheme. The features are extracted in three distinct stages, as shown in Figure 4.4. Details of which are in the following subsections.

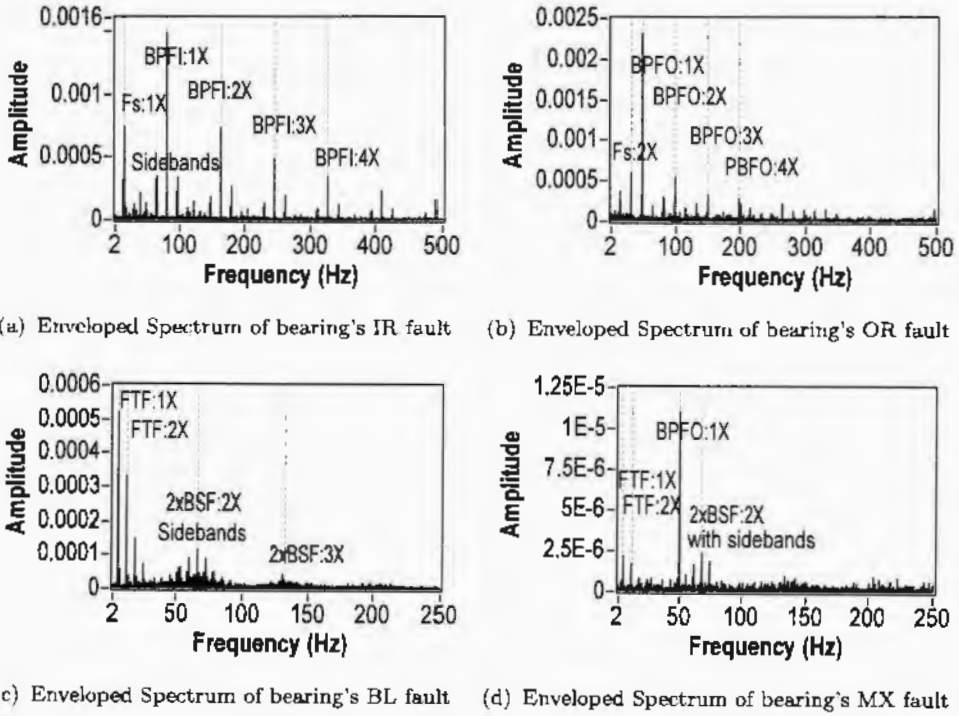

FIGURE 4.3: Enveloped spectra of bearing's faults

4.2.2.1 Data Segmentation

At first stage, each acquired vibration signal or sample of every fault was segmented into n segments or sub-samples ($n=30$ here). As the motor speed was 16.67 Hz, thus each segment holds vibration history of more than 5.5 revolutions of the shaft. In this way, the segments contained a valid sample length to compute trustworthy statistical features.

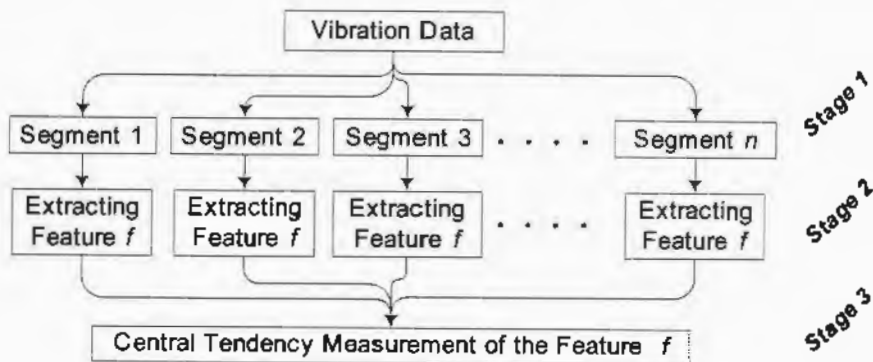

FIGURE 4.4: CT-based Feature Extraction of single feature

4.2.2.2 TD Feature Extraction from the Segments

Ten TD features were extracted from every segment. The features include RMS, variance, skewness, kurtosis, CF, IF, SF, median and range. The features are described mathematically in Section 1.1.

4.2.2.3 Obtaining CT of the Features

The presented method utilized CT of TD features to judge which part of signal is most appropriate to extract the features. Section already explained the CT measures. This research uses median value as central tendency measure. The respective part of vibration signal is taken to proceed further, which produces median value of a feature

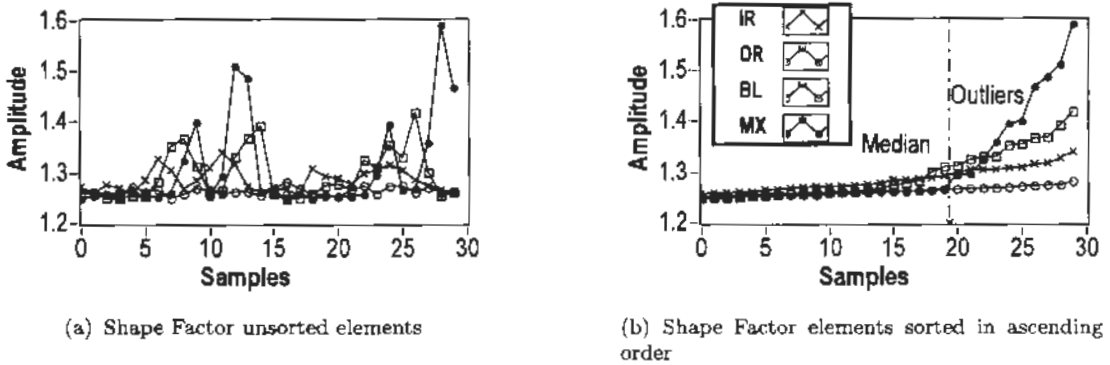

FIGURE 4.5: Shape Factor feature extracted from every faulty signal

Figure 4.5(a) shows range feature extracted from vibration samples of every fault. The feature values are varying due to fluctuations in random vibration signals. Figure 4.5(b) shows the same elements sorted in ascending order. Median values of the feature from every fault are nearly insensitive to these outliers. Therefore, the proposed CTBFE method considers the median values of TD features as the most accurate features to recognize bearing's faults patterns, i.e. the values that are unaffected by undesired fluctuations. This choice indirectly points out the most appropriate vibration sub-sample or portion, which produces the feature's median value. In other words, the proposed method picks a particular vibration

$$\text{Norm. Value} = 3 \times \left(\frac{\text{Value} - \text{min value in a set of CVs}}{\text{max value in CVs} - \text{min value in CVs}} \right) \quad (5.1)$$

The sets of NCVs are exploited further to select most informative features and rule-set formation. Separating distances between the NCVs in a specific set was used to develop the feature selection mechanism. A feature capable of well separating its respective NCV was considered worthy for the diagnostic process. The rule-based algorithm is elaborated via flowchart in Figure 5.2.

First of all, values in each set was sorted in an ascending order. This provided relative distances between every pair, which represented any two adjacent NCVs lie in a set. Hence, there exists three pairs in any NCV-set. As the normalization in a set of four NCVs is done from 0 to 3, thus an ideal distance between each pair was 1. Increasing the distance between any pair above 1 will result in reduction of distances between the other neighboring pairs.

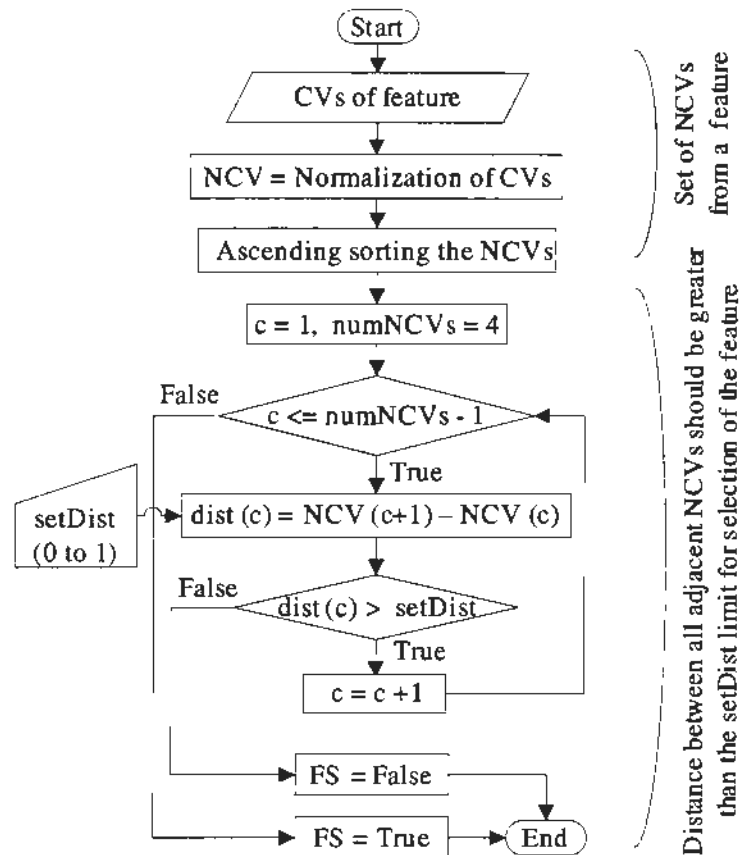

FIGURE 5.2: Flow chart of a feature evaluation procedure

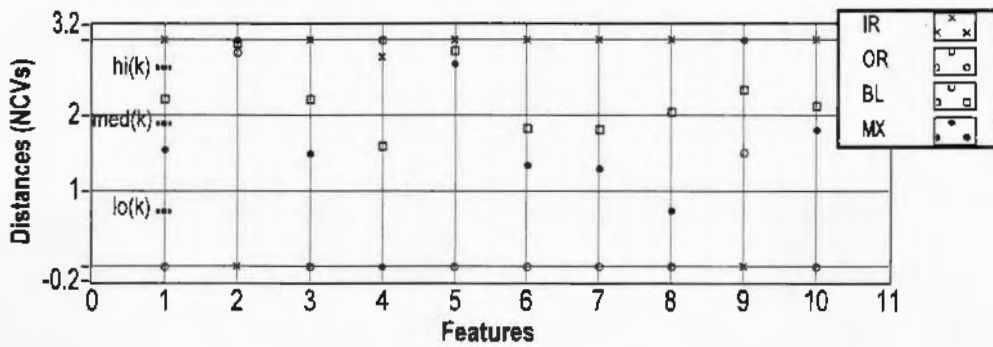

FIGURE 5.3: Relative distances among respective NCVs of every feature

Figure 5.3 shows distances among the NCVs of respective sets, i.e. the NCVs produced by every feature. Horizontal axis of the XY-graph indicates the features by the assigned numbers for convenience. The numbers 1 to 10 stands for the ten features RMS, mean, variance, skewness, kurtosis, CF, IF, SF, median and range respectively. For the selection of a particular feature, a minimum distance-limit between all the pairs is required to be fulfilled in the respective set of NCVs to which that feature belonged. To provide flexibility, a user defined parameter, named as *setDist*, was defined to set the limit from 0 to 1. In case the separating distances between all pairs in a set of NCVs were greater than the defined limit, then that particular feature was chosen to which the NCVs belonged (FS = True). For instance, setting the value of *setDist* parameter equal to 0.66, the feature selection algorithm returned three top ranked features that included RMS, variance and shape factor respectively (numbered as 1, 3 and 8 in Figure 5.3 respectively). Though, several features demonstrated reasonably good separation among their respective NCV-sets, as shown by minimum distances in Table 5.1. The features include RMS, median, variance, SF, CF and IF. When the *setDist* value approaches to its utmost setting, i.e. 1, then the criteria of feature evaluation turn out to be more strict for a feature to be selected for further processing and vice versa.

4.2.2.2 TD Feature Extraction from the Segments

Ten TD features were extracted from every segment. The features include RMS, variance, skewness, kurtosis, CF, IF, SF, median and range. The features are described mathematically in Section 1.1.

4.2.2.3 Obtaining CT of the Features

The presented method utilized CT of TD features to judge which part of signal is most appropriate to extract the features. Section already explained the CT measures. This research uses median value as central tendency measure. The respective part of vibration signal is taken to proceed further, which produces median value of a feature

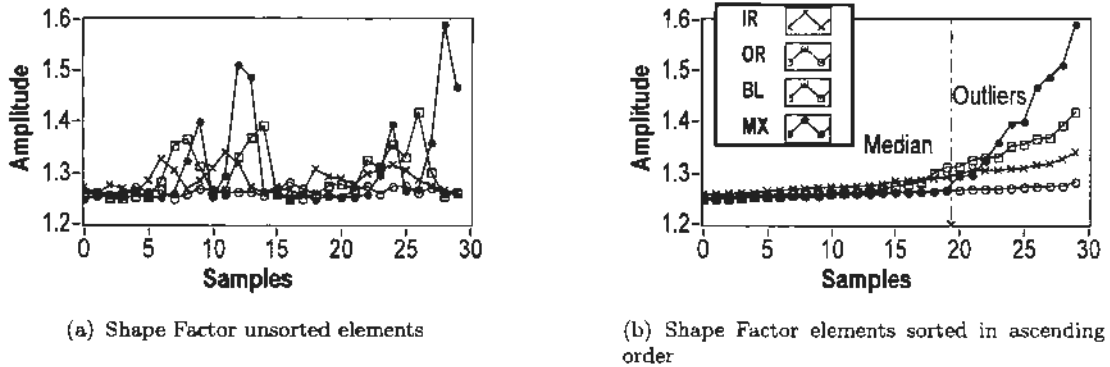

FIGURE 4.5: Shape Factor feature extracted from every faulty signal

Figure 4.5(a) shows range feature extracted from vibration samples of every fault. The feature values are varying due to fluctuations in random vibration signals. Figure 4.5(b) shows the same elements sorted in ascending order. Median values of the feature from every fault are nearly insensitive to these outliers. Therefore, the proposed CTBFE method considers the median values of TD features as the most accurate features to recognize bearing's faults patterns, i.e. the values that are unaffected by undesired fluctuations. This choice indirectly points out the most appropriate vibration sub-sample or portion, which produces the feature's median value. In other words, the proposed method picks a particular vibration

sub-sample for feature extraction to take part in pattern recognition process, while discarding the rest of vibration sub-samples.

4.2.3 Fault Classification

Supervised learning based PR-model was employed at final stage of the proposed methodology. SVM, bayesNet, decision table and decision tree were used separately to judge the performance of CTBFE method. At first stage, a classifier is trained using known data examples or instances and then employed for testing unknown data. Section 3.3.3 already explained the classifiers, the supervised learning and classification procedure.

4.3 Results and Discussion

Vibration data was acquired from a set of ball bearings containing localized faults using MFS. The intention was to identify these faults using PR methods with TD statistical features. An important phenomena was observed that fluctuations may be occurred in random vibration signals, and statistically calculated values of the TD features can be altered consequently [129].

Figure 4.6 shows the fluctuations present in the vibration signals acquired from faulty bearings. The reasons behind the occurrence of this particular phenomena are outside the scope of this study. However, the fluctuations may not be related to bearing's localized faults, and can reduce the fault classification ability of classifiers [129]. The inaccurate feature values made the fault identification difficult for the classifiers. Thus, the CTBFE method was developed that ensure the provision of reliable and accurate TD features to the diagnostic models. The proposed method selects the most appropriate portion of a time domain signal before extracting any feature to take part in PR process. The diagnostic capability of the classifiers was improved considerably.

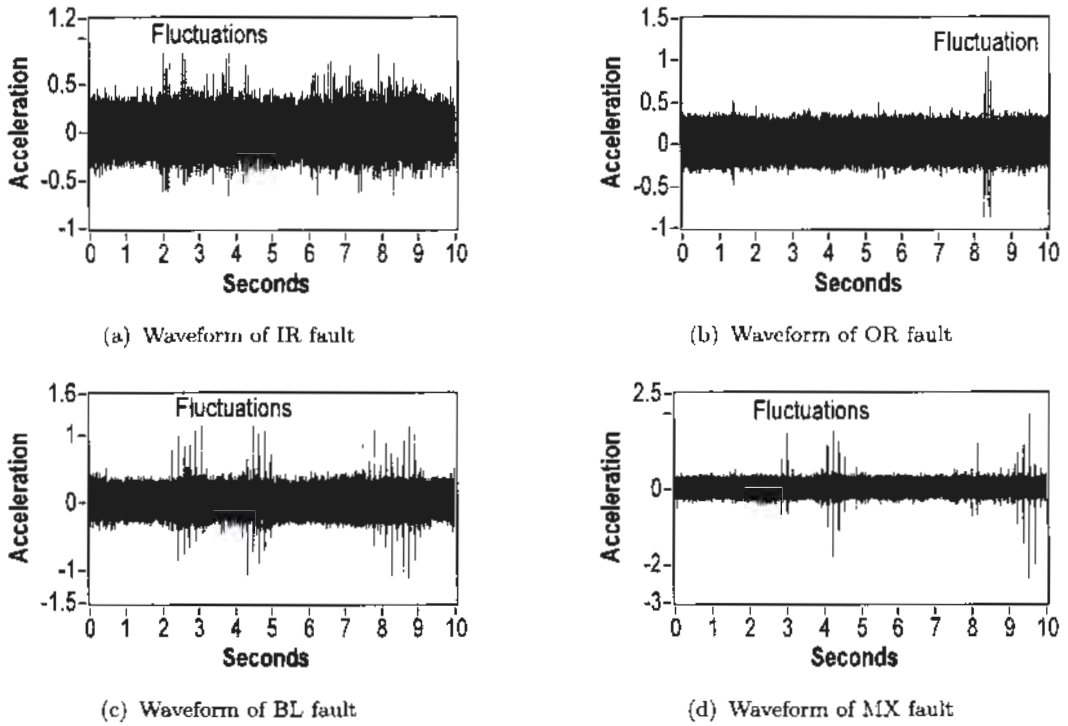

FIGURE 4.6: Waveforms of bearing faults

Unlike the conventional way, the TD features were not extracted directly from vibration signal or sample. An acquired vibration signal was initially segmented or divided into suitable number of sub-samples, as already discussed in Section 4.2.2. Then at the next stage, any TD feature was extracted from every segment, forming distribution of that feature. The feature distribution might contain outlying values extracted from the segments having fluctuations. Finally, median value of the distribution was chosen as a reliable value of the feature used by the classifier later. Remaining values of that feature were discarded. In other words, a portion of time domain vibration signal, which produced median value in the feature distribution was considered as the most appropriate part of the signal to extract that particular feature for classifier. Similarly, every vibration signal or sample, acquired from different faulty bearings, were processed, and data-set was prepared for the supervised learning and testing of a classifier using all the TD features.

Figure 4.7 shows the RMS and median features extracted from all the vibration samples acquired against every fault, i.e. forty samples of vibration data against

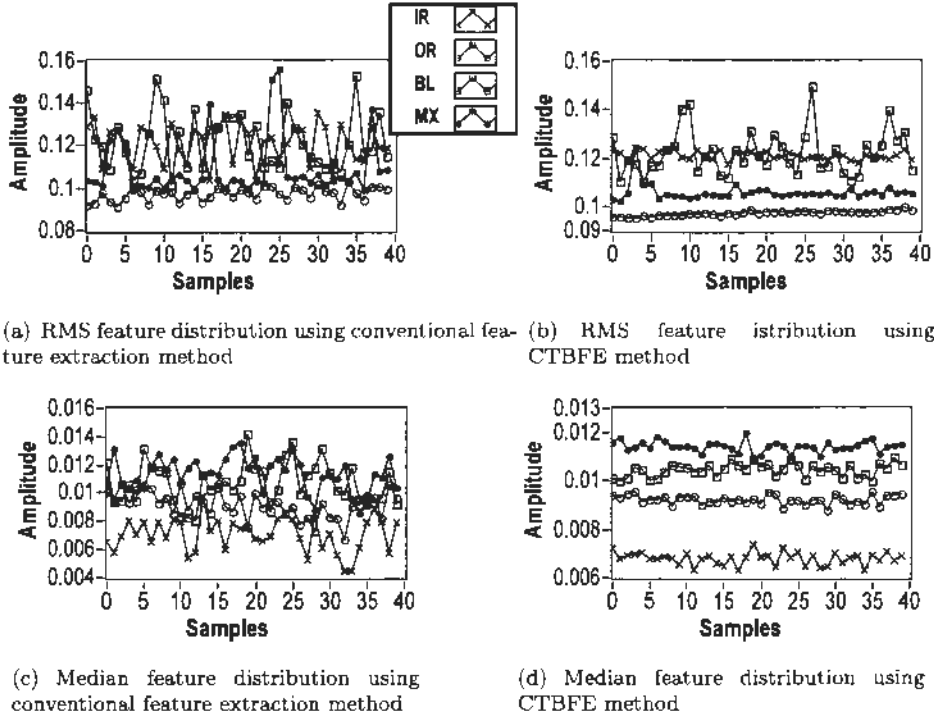

FIGURE 4.7: Distribution of features for every faults. using conventional feature extraction and CTBFE methods

each fault as already explained in Section 4.2.1. Figures 4.7(a) and 4.7(c) shows fluctuated values of RMS and median features respectively due to presence of fluctuations in the samples. Overlapping among the median elements can be observed, extracted conventionally against different fault classes. On the other hand, figures 4.7(b) and 4.7(d) show much smoother and stable values of RMS and median features respectively, extracted using CTBFE method against every fault.

TABLE 4.2: Fault classification accuracies (%) demonstrated by the classifiers using TD features extracted through conventional method, CTBFP method and CTBFE method

TD Features	SVM	BayesNet	D. Table	D. Tree
Conventional	76.3	73.1	73.8	75.6
CTBFP-based	94.4	93.1	93.8	93.1
CTBFE-based	96.8	95.6	96.3	95.3

Table 4.2 shows the results in terms of fault classification accuracies produced by the SVM, bayesNet, decision table and decision tree. The classifiers provides quite low classification accuracy when trained over the conventional TD features. The above mentioned overlapping may be reason of misclassification. On the other

hand, the CTBFE method provides the most accurate results, even higher than that of CTBFP method [129]. Every classifier considerably enhances its classification accuracy using the features extracted through CTBFE method. Table 4.3 shows the CTBFE-based instances fed to the classifiers. Unlike the CTBFP method, which examines a vibration sample whether to adopt or discard before incorporating classifier in a PR system, the CTBFE method preserves vibration sample or the data instance. In other words, every vibration data sample was taken into account for the training and testing of classifier. The CTBFE method locally examines the vibration sample to find the best portion to extract a particular feature rather. As the proposed method operated at feature extraction-level, thus few values in any feature distribution were processed. This makes the method computational efficient over the conventional method of pre-processing the big TD raw vibration data. Therefore, the proposed method more feasible to apply, especially in on-line systems.

TABLE 4.3: Sample instances

RMS	Mean	Variance	Skewness	Kurtosis	CF	IF	SF	Median	Range	Class
0.104251	0.010171	0.010769	-0.060896	3.107096	4.180617	5.262083	1.255357	0.011670	0.855635	MX
0.097082	0.009646	0.009326	0.024434	3.111147	4.304330	5.431385	1.260813	0.009161	0.786403	OR
0.114673	0.010069	0.013055	-0.001619	3.487579	5.580402	7.072814	1.274444	0.010164	1.080577	BL
0.109926	0.009739	0.011995	-0.028010	3.477397	4.880355	6.215002	1.272296	0.010298	1.047131	BL
0.107676	0.010239	0.011491	-0.063840	3.213316	4.559395	5.753273	1.260497	0.011645	0.932939	MX
0.123887	0.006732	0.015308	0.039166	4.130151	5.402507	7.052314	1.290309	0.006705	1.238731	IR
0.096585	0.009771	0.009227	0.028402	3.106420	4.408249	5.563598	1.260118	0.009311	0.797831	OR
0.117095	0.006637	0.013665	0.061755	3.848648	5.270918	6.751742	1.283447	0.006443	1.126882	IR
0.097541	0.009738	0.009424	0.021167	3.089156	4.238921	5.338348	1.258366	0.009404	0.792569	OR
0.117171	0.009918	0.013623	-0.034957	4.090413	6.121256	7.859428	1.288918	0.010311	1.340206	BL
0.123120	0.006549	0.015118	0.018975	4.087831	5.219351	6.697593	1.289506	0.006412	1.200625	IR
0.104262	0.010232	0.010764	-0.053463	3.063545	4.191004	5.259959	1.255473	0.011146	0.852375	MX
0.098299	0.009691	0.009569	0.009942	3.083072	4.241622	5.326563	1.259690	0.009423	0.791360	OR
0.105448	0.010175	0.011023	-0.075306	3.250603	4.788783	6.073055	1.263119	0.011103	0.923451	MX
0.123027	0.010081	0.015032	-0.093497	5.105299	7.220242	9.686619	1.312410	0.010678	1.717667	BL
0.118982	0.006575	0.014116	0.018851	3.659112	4.876021	6.244959	1.276700	0.006698	1.076432	IR
0.097786	0.009659	0.009464	0.047652	3.148428	4.410911	5.577425	1.261922	0.008843	0.824528	OR
0.128342	0.009797	0.016382	-0.068345	6.964402	8.247482	11.168003	1.348729	0.010348	1.993567	BL
0.098446	0.009844	0.009596	0.028482	3.100508	4.170840	5.244687	1.260199	0.009236	0.779015	OR
0.119826	0.006562	0.014313	0.011161	3.839070	5.185884	6.588230	1.284385	0.006910	1.135910	IR
0.103058	0.010192	0.010521	-0.073351	3.107329	4.346817	5.480032	1.256962	0.011770	0.859868	MX
0.104754	0.010201	0.010868	-0.060541	3.132232	4.318295	5.446635	1.256244	0.011209	0.872841	MX
0.097683	0.009828	0.009443	0.014793	3.155368	4.285214	5.426932	1.262211	0.009473	0.802919	OR
0.118858	0.009756	0.014034	-0.050718	5.433235	6.766725	9.134587	1.323466	0.010379	1.653648	BL
0.120009	0.006516	0.014364	-0.005199	3.637722	4.789050	6.092252	1.276882	0.007023	1.058688	IR
0.097517	0.009707	0.009409	0.037788	3.076821	4.304325	5.426315	1.259559	0.008862	0.781715	OR
0.106686	0.010117	0.011280	-0.054581	3.286501	4.938892	6.205985	1.262083	0.011439	1.007855	MX
0.111537	0.009981	0.012329	-0.031095	3.464394	5.006476	6.372134	1.272795	0.010679	1.019008	BL

Finally, background noise was added to the acquired vibration signals at different SNRs. The purpose was to examine the robustness of the CTBFE method against possible background noise. Table 4.4 shows a comparative accuracies using SVM with differentially extracted raw TD features, CTBFP-based features

TABLE 4.4: Comparison of the influence of background noise on SVM classification accuracy (%)

TD Features	40dB	30dB	20dB	10dB	5dB
Conventional	76.3	75.6	75.0	73.6	70.2
CTBFP-based	94.4	94.4	93.1	92.5	91.8
CTBFE-based	96.8	96.8	96.3	96.3	96.1

and CTBFE-based features. The results are evident that the CTBFE method is considerably immune to strong background noise.

In conclusion, it is worthwhile to disassociate the unrelated vibration signal fluctuations before extracting TD features for better results. The proposed method provides an effective way to extract accurate features for reliable PR of REB's localized faults.

4.4 Summary

Vibration-based PR methods have been utilized to identify localized faults of REB using statistical TD features. It is observed that undesired fluctuations present in random vibration signals consequently swung the statistical values of TD features. It has also been observed that these fluctuations might not be related to REB's localized faults, and employment of inaccurate feature values in PR systems might be the source of misleading the supervised learning based classifiers. Thus, unlike the conventional extraction of TD features, the CTBFE method is proposed to supply accurate and reliable feature values to the diagnostic models. Only the respective appropriate portions of vibration signals have been utilized to extract the desired TD features for the fault classification process. Variety of classifiers have been employed to evaluate the proposed methodology, and the results were evident that all the classifiers were performed better when utilized the CTBFE-based features. Moreover, the proposed method has shown its robustness against the strong background noise. When compared to the most related existing CTBFP method, the proposed CTBFE method provides better fault classification accuracy.

Chapter 5

Rule-based Identification of Bearing Faults using CTBFE method

The TD features extracted through CTBFE method in Chapter 4 are utilized to develop a new diagnostic scheme with the intent classify localized faults of REB. The scheme employs CTBFE-based features to develop decision making procedure. Accurate and stable feature values are named as CVs here in this Chapter 5. Thus, every feature extracted from vibration samples of different faulty bearings, produces a set of CVs. Number of CVs in the set are equal to the number of fault classes involved in the diagnostic process. Separating distances among the normalized CVs, i.e. NCVs in a distinct set, are exploited then to choose the salient features. Finally, the respective sets of NCVs, produced by the selected features, are processed to define the threshold limits for the formation of rule-set and decision making. The RBDS is robust against strong background noise and offers real-time processing and may be an effective alternative to costly training-based classifier.

5.1 RBDS Methodology

The proposed methodology work in four steps, as shown in Figure 5.1. The first two steps of the methodology are already covered in Chapter 4. Data acquisition and validation process is explained along with the CTBFE method. The outcome of CTBFE method are utilized to form sets of NCVs. For instance, four vibration samples are taken from four bearing faults. A TD feature like RMS is extracted from each vibration sample using CTBFE method. Thus, the RMS feature produces a set of four values, which are known as CVs against the respective faults. The CVs are normalized later to obtain a set of NCVs for the RMS feature. In this way, every feature produces a set of NCVs. These sets are processed at the third step to select most informative features using a newly presented distance based method. At last step, these sets of NCVs, which are obtained using selected features only, are exploited to develop rule-based decision making criterion. Detailed description of the presented scheme is given in the following subsections.

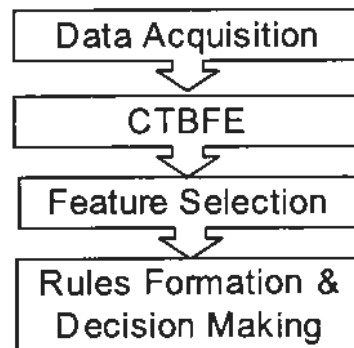

FIGURE 5.1: Block diagram of the RBDS

5.1.1 Feature Selection

Most informative features were chosen for the formation of the rules. This ensures efficient and reliable diagnosis. As mentioned earlier, every feature produces a set of CVs that are equal in number to the bearing's fault classes. This study dealt with four bearing faults. Thus, for convenient separation of these faults, every set of CVs was then normalized between 0 and 3 using the relation below.

$$Norm. Value = 3 \times \left(\frac{Value - \text{min value in a set of CVs}}{\text{max value in CVs} - \text{min value in CVs}} \right) \quad (5.1)$$

The sets of NCVs are exploited further to select most informative features and rule-set formation. Separating distances between the NCVs in a specific set was used to develop the feature selection mechanism. A feature capable of well separating its respective NCV was considered worthy for the diagnostic process. The rule-based algorithm is elaborated via flowchart in Figure 5.2.

First of all, values in each set was sorted in an ascending order. This provided relative distances between every pair, which represented any two adjacent NCVs lie in a set. Hence, there exists three pairs in any NCV-set. As the normalization in a set of four NCVs is done from 0 to 3, thus an ideal distance between each pair was 1. Increasing the distance between any pair above 1 will result in reduction of distances between the other neighboring pairs.

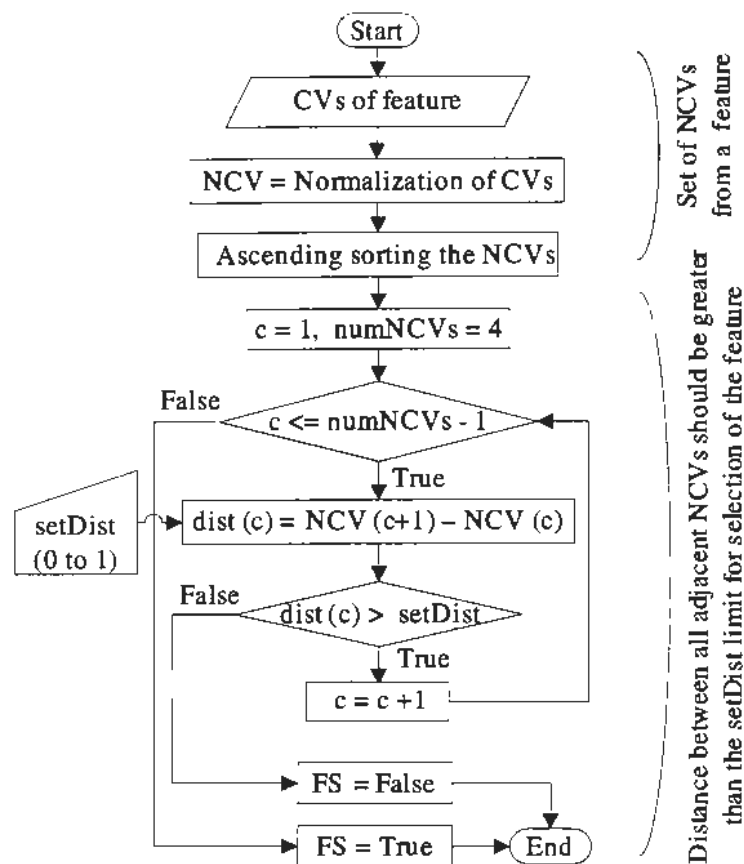

FIGURE 5.2: Flow chart of a feature evaluation procedure

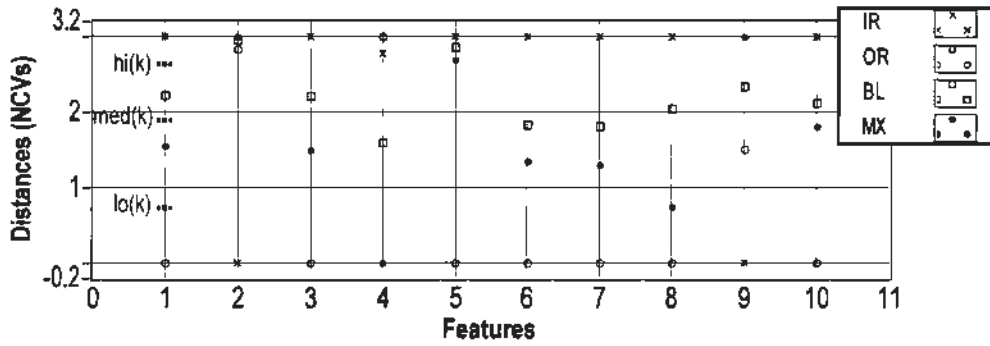

FIGURE 5.3: Relative distances among respective NCVs of every feature

Figure 5.3 shows distances among the NCVs of respective sets, i.e. the NCVs produced by every feature. Horizontal axis of the XY-graph indicates the features by the assigned numbers for convenience. The numbers 1 to 10 stands for the ten features RMS, mean, variance, skewness, kurtosis, CF, IF, SF, median and range respectively. For the selection of a particular feature, a minimum distance-limit between all the pairs is required to be fulfilled in the respective set of NCVs to which that feature belonged. To provide flexibility, a user defined parameter, named as *setDist*, was defined to set the limit from 0 to 1. In case the separating distances between all pairs in a set of NCVs were greater than the defined limit, then that particular feature was chosen to which the NCVs belonged ($FS = True$). For instance, setting the value of *setDist* parameter equal to 0.66, the feature selection algorithm returned three top ranked features that included RMS, variance and shape factor respectively (numbered as 1, 3 and 8 in Figure 5.3 respectively). Though, several features demonstrated reasonably good separation among their respective NCV-sets, as shown by minimum distances in Table 5.1. The features include RMS, median, variance, SF, CF and IF. When the *setDist* value approaches to its utmost setting, i.e. 1, then the criteria of feature evaluation turn out to be more strict for a feature to be selected for further processing and vice versa.

TABLE 5.1: Minimum distances between any pair in a set of NCVs

Feature No.	Feature	Distance (0 to 1)	Status
1	RMS	0.6731	Selected
2	Mean	0.0452	Discarded
3	Variance	0.7177	Selected
4	Skewness	0.2268	Discarded
5	Kurtosis	0.1402	Discarded
6	Crest Factor	0.4843	Discarded
7	Impulse Factor	0.5167	Discarded
8	Shape Factor	0.7444	Selected
9	Median	0.6568	Discarded
10	Range	0.3146	Discarded

5.1.2 Rule Formation and Decision Making

The corresponding NCV-sets chosen against the three salient features were used to construct rules to identify bearing faults. Three most important features were RMS, variance and shape factor respectively. As there were three pairs in a NCV-set, which contains four values. Thus, three reference limits (refNCVs) were obtained by averaging the NCVs of each pair, as shown graphically for RMS feature in Figure 5.3. The reference limits $lo(k)$, $med(k)$ and $hi(k)$ were obtained for every feature; $k = 1$ for RMS feature. The rule formation procedure utilized these references to make decisions, as illustrated in Algorithm 1. The algorithm generated only four rules for the purpose, i.e. single rule for the identification of single fault.

To test the unknown vibration sample, three selected TDFs were extracted from the test sample also, i.e. RMS, variance and shape factor. The features were also processed through the feature processing step explained already. Three test CVs were produced against the three salient features. The test CV were also normalized using the same Equation 5.1, i.e. between 0 and 3. During the normalization process, the same corresponding values of min and max were utilized that were obtained using the reference CV-sets. Finally, each of the normalized test CV (testNCV) was compared with its corresponding reference set (refNCVs) to recognize the fault type to which the particular vibration sample might belonged. For

Algorithm 1 Rules generation using selected features

Input: $nFeatures=3$, $nNCVs=4$, $refNCV[3, 4]$ (3 chosen sets of NCVs, each one contains 4 references), $testNCV[3]$ (Set of 3 test NCVs obtained from 3 chosen features)

Output: *Fault type*

```
for  $k = 1 \rightarrow nFeatures$  do
  for  $m = 1 \rightarrow nNCV - 1$  do
     $limit(m) = (refNCV(k, m) + refNCV(k, m + 1))/2$ 
  end for
   $lo(k) = limit(1)$ 
   $med(k) = limit(2)$ 
   $hi(k) = limit(3)$ 
end for
if  $testNCV(1) > hi(1)$  and  $testNCV(2) < lo(2)$  and  $testNCV(3) > hi(3)$ 
then Fault type = IR fault
else if  $testNCV(1) < lo(1)$  and  $testNCV(2) > hi(2)$  and  $testNCV(3) < lo(3)$ 
then Fault type = OR fault
else if  $testNCV(1) > med(1)$  and  $testNCV(1) < hi(1)$  and  $testNCV(2) > med(2)$  and  $testNCV(2) < hi(2)$  and  $testNCV(3) > med(3)$  and  $testNCV(3) < hi(3)$ 
then Fault type = BL fault
else if  $testNCV(1) > lo(1)$  and  $testNCV(1) < med(1)$  and  $testNCV(2) > lo(2)$  and  $testNCV(2) < med(2)$  and  $testNCV(3) > lo(3)$  and  $testNCV(3) < med(3)$ 
then Fault type = MX fault
else Fault type = Unidentified fault
end if
```

example, the test NCV of RMS feature were compared with refNCVs, which were obtained using the RMS feature extracted from reference vibration data-set.

5.2 Results and Discussion

The CTBFE method was utilized further to generate rules with the intent to classify localized fault in ball bearing. A test rig was used to acquire vibration data for every fault of the bearing. The TD features or CVs were extracted via CTBFE method explained already in Chapter 4. The CVs were used as references to form rules and judge the type of fault. Importantly, only the chosen salient features participated in the diagnostic process to achieve efficient and reliable results.

To evaluate the performance of the RBDS, total 160 vibration test samples were captured, i.e. 40 samples for each fault. Every test sample was processed via feature processing step. Each sample then produced a set of three testNCVs against the selected three features. Thus, the Algorithm 1 utilized 3 160 testNCVs in total. The algorithm provides 95.6% accuracy of fault identification. Out of 160 samples, only three vibration samples of BL fault and four samples of MX fault were remained unidentified.

To evaluate the performance of the RBDS, a supervised learning model SVM was implemented. The training data was prepared using the same vibration data that was used to obtain reference NCVs. In the same way, test data was prepared from the same vibration data that was used to test the proposed RBDS. All the ten TDFs were transformed into instances, i.e. by adding fault labels. In this way, total 160 instances, 40 instances for each fault class, were fed to the classifier. The multi-class SVM produced only 76.3% fault classification accuracy applying 10-fold cross validation method for the training and testing purpose. Table 5.2 summarizes the vibration samples involved for the RBDS and SVM-model.

TABLE 5.2: Vibration data samples used for RBDS, and for SVM model

Vibration Samples	IR	OR	BL	MX
RBDS References	1	1	1	1
RBDS Testing	40	40	40	40
SVM Train & test	40	40	40	40

Finally, the background noise was added to the vibration signals at various SNRs to prove the robustness of the presented method against the background noises. Fault classification accuracies using SVM and RBDS are compared in Table 5.3. The results obtained are evident that the RBDS provides considerable immunity to the added noise.

TABLE 5.3: Effect of background noise on the fault classification accuracies (%) from RBDS and SVM

Features	40dB	30dB	20dB	10dB	5dB
SVM	76.3	75.6	75.0	73.3	70.2
RBDS	95.6	95.6	95.6	94.4	94.4

5.3 Summary

The TD features extracted via CTBFE method were exploited to develop a new RBDS to identify localized faults in ball bearing. Several vibration samples were acquired to investigate bearing's four faults with the help of a test rig. Distances between the CTBFE-based NCVs in respective sets were exploited to build a feature selection mechanism and generate simple rule-set for identification of the faults. The RBDS produced excellent results, even in the presence of considerable background noises. The presented methodology may be an efficient alternative to the costly supervised learning based PR-based fault diagnosis.

rather to obtain reliable TD feature values. The CTBFE method overcome the inherited limitations of applying CTBFP method in situations where availability of data size is limited. The method does not discard the affected instances but utilized every available vibration sample. It selects the most appropriate portion or sub-sample of a vibration sample for the extraction of TD features. This strategy ensures the supply of very accurate feature values to a classifier for truthful decision making. In addition to efficiency, the presented method provided significant immunity to possible fluctuations and background noises in vibration signal. Apart from preserving number of instances, the CTBFE provided even more accurate results compared to that of CTBFP method. However, the CTBFP is more efficient when the availability of data is not restricted. The CTBFE demonstrated 96.8% accuracy at maximum using the multi-class SVM to identify four faults of REB employing ten TD features. Whereas, the classifier could provide only 76.3% accuracy when employed the same raw TD features. Both the above mentioned methods disassociated the effect of unrelated vibrations adequately from sensitive TD features before the start of supervised learning process. It is worth mentioning that only fewer values of features were required to processed than with conventional pre-processing techniques to enhance the fault classification accuracy.

The CTBFE method is exploited further to present a RBDS to identify localized faults in REB. The method utilized the accurate and stable feature values extracted through CTBFE method. The CTBFE-based feature values, acted as CVs, were obtained against the respective bearing faults. Distances between NCVs in the respective sets were employed to build a kind of feature selection mechanism, and to generate simple rule-set for the fault identification. The RBDS produced excellent results and offered an unique alternative to the existing PR-based fault diagnosis. The method produced 95.6% accurate results employing only three salient features.

Finally, the TD features were also processed to identify rotor's most common faults, such as unbalance and misalignment. Confirming the unbalanced state of rotor before the maintenance activity is important as balancing procedure is based on weight adjustment technique. Misjudging misalignment with unbalance may

lead to additional problems in machinery. This study exploited the difference of behavior exhibited by these faults in terms of vibration transmission in radial and axial directions. Combining the multi-axis TD features provides very accurate results. Every pair of alike features were processed adequately to produce again a single robust feature. The method enhanced the accuracy of the binary-SVM model to 100% using six multi-axis features only while maintaining the length of feature vector. Whereas, the classifier provides only 83.3% classification accuracy employing the single axis same TD features.

7.1 Future Work

- The CTBFP and CTBFE are applied to localized faults in REB. Due to providing very accurate results, the future research may continue to apply these methods to diagnose other faults in rotating machinery, for example gear faults. However, care must be taken before isolating the fault under investigation from any undesired data that any related and valuable information might not be lost.
- The CTBFP method processes the features efficiently via outlier detection by implementing the MOD function, discussed in Chapter 3. The affected instances were pruned at next stage of the algorithm based on the MOD outcome. The MOD's parameter *scale* determines the threshold to categorize any feature value as outlier. The parameter acts as trade-off between the resulting accuracy and the size of remaining data-set used in supervised learning process. The present research used a standard threshold value suggested in the literature due to limited resources. However, value of the parameter may be adjusted according to the nature of data-set or application of other rotating component of machinery. The future research should investigate the adaptive value of the *scale* parameter using some optimization technique before employing the MOD function for best results.

TABLE 5.3: Effect of background noise on the fault classification accuracies (%) from RBDS and SVM

Features	40dB	30dB	20dB	10dB	5dB
SVM	76.3	75.6	75.0	73.3	70.2
RBDS	95.6	95.6	95.6	94.4	94.4

5.3 Summary

The TD features extracted via CTBFE method were exploited to develop a new RBDS to identify localized faults in ball bearing. Several vibration samples were acquired to investigate bearing's four faults with the help of a test rig. Distances between the CTBFE-based NCVs in respective sets were exploited to build a feature selection mechanism and generate simple rule-set for identification of the faults. The RBDS produced excellent results, even in the presence of considerable background noises. The presented methodology may be an efficient alternative to the costly supervised learning based PR-based fault diagnosis.

Chapter 6

Classification of Unbalance and Misalignment Faults in Rotor using Multi-Axis Time Domain Features

Rotor unbalance and misalignment faults are usually difficult to identify using conventional vibration-based frequency analysis methods. Main reason is that both faults often produce similar sort of frequency spectra. The balancing procedure of an unbalanced rotor is based upon attachment or removal of certain amount of weight to or from a particular location of the rotor. Misjudging the misalignment fault with the unbalance, may causes additional problems in the rotor due to different maintenance strategies. Therefore, confirming the unbalance state of rotor is extremely important prior to take any corrective action. This study utilizes PR-based fault classification technique for the problem at hand using TD features [155]. Same classifiers, i.e. SVM, bayesNet, decision table, and decision tree, are used to determine the effectiveness of the proposed method, which provide 100% accuracy. Major contributions of this research include:

- Employing multi-axis TD features for accurate identification of unbalance and misalignment faults.
- The multi-axis feature processing mechanism produce more robust features for efficient fault diagnosis.
- 100% accurate results are achieved.

The chapter is organized as follows. Section 6.1 explains the theory behind rotor faults. The proposed scheme is elaborated in Section 6.2. Section 6.3 discusses the results and findings of the presented method. Finally, the study is summarized in Section 6.4.

6.1 Rotor Faults

Unbalance is the most common fault in rotor that occurs due to uneven mass distribution around rotor's rotation center. Unbalance force pulls the rotor towards a specific orientation or location, which is also known as heavy spot. Severity level of measured vibration and rotor's speed correlate directly with the amount of unbalance. If the rotational speed doubles and the amount of unbalance remains constant, then the centrifugal forces will increase by a factor of four and consequently the vibration amplitudes would also increase accordingly (Refer to Equations 2.5 and 2.6). The dynamics admit the attachment or removal of certain amount of weight to or from that specific rotor's location to balance out the unwanted force. Usually, radial vibrations dominates in case of unbalance fault, which produce primary harmonic of vibration (1X) that is higher than that of normal rotor [36].

Misalignment is the next common fault to unbalance. Vibration due to misalignment fault is often produced by reactive forces in the coupling, when two coupled shafts are not perfectly collinear. Unlike the unbalance, correlating the effects of misalignment with vibration amplitude can be difficult. Types of misalignments

along with more details of the fault can be found in second part of Section 2.2.2. Present study deals with only angular misalignment type, which generate forces in both radial & axial directions. Consequently, the vibrations acquired from both axes contain information about the fault. The vibrations due to misalignment fault generally presents the fundamental harmonic at $2X$ [36]. Theoretical aspect of these rotor faults is already covered in Section 2.2.2.

6.2 Proposed Methodology

The proposed method works in four steps, which are shown in the block diagram in Figure 6.1. Following subsections explain each of the step.

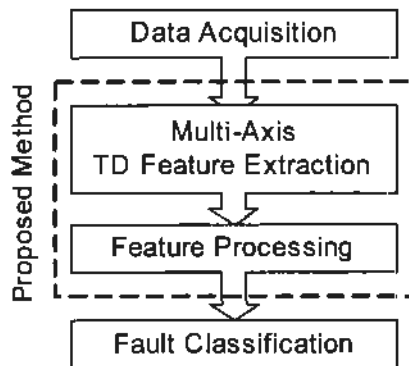

FIGURE 6.1: Block diagram of Multi-axis features based fault diagnosis of rotor

6.2.1 Data Acquisition

At first step, a machine fault test rig was used to generate vibration signals for unbalance and misalignment faults. Two piezoelectric accelerometers were mounted at the housing of out-board bearing. Radial measurement is taken from vertically mounted sensor (Radial-V) whereas the other one is taken from axial direction simultaneously, as shown in Figure 6.2. Seventy samples were acquired at the rate of 40K Samples/sec. Duration of each sample was 3 seconds, while the motor speed was kept at 1400 RPM (23.3 Hz).

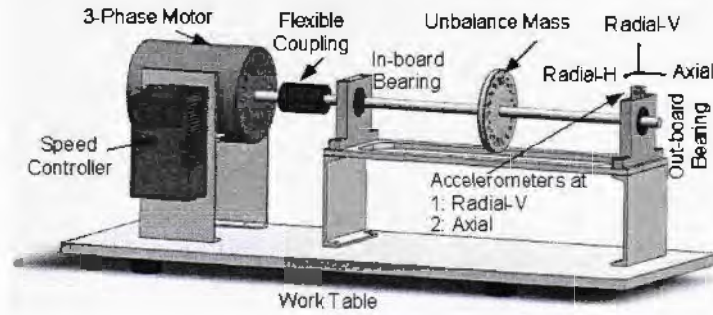

FIGURE 6.2: Schematic of the experimental setup

Figure 6.3 shows the spectra of both the rotor faults. Figure 6.3(a) shows spectrum of unbalance fault containing harmonic at 1X, whereas 6.3(b) shows spectrum of misalignment fault containing two harmonics at 1X and 2X. The typical spectra of both the faults validates the data.

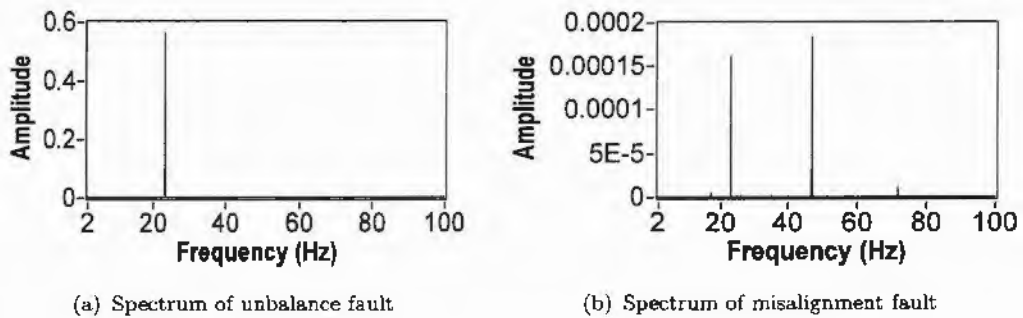

FIGURE 6.3: Spectra of rotor faults

6.2.2 Multi-Axis TD Feature Extraction

At second step, TD features were extracted from each of the radial vibration sample and axial vibration sample to form data set. Ten TD features are utilized that include RMS, mean, variance, skewness, kurtosis, CF, IF, SF, median and range. The features are already described mathematically in Section 1.1.

6.2.3 Feature Processing

The third step is the key step that implements the feature processing mechanism to feed the most appropriate features to classifier. The alike features are subtracted

to calculate a sort of signed distance to obtain new resultant feature. For example, the RMS-Axial is subtracted from RMS-Radial to produce resultant single feature again, i.e. RMS-Multiaxis. In this way, the length of feature vector is remained the same, i.e. again ten features in an instance. Below is the relation used to process every feature.

$$f(i) = \sum_{i=1}^N \left(f_{RADIAL}(i) - f_{AXIAL}(i) \right) \quad (6.1)$$

where $f(i)$ represents i^{th} feature, and $N=10$ in our case.

Six TD features were selected in this research by employing attribute evaluation method. The reason to reduce the dimensionality of the feature vector in this study is that even six multi-axis features produced 100% accuracy to identify two fault classes. This is just to make the comparison purposeful, i.e. comparison between multi-axis and single-axis usage of features. Otherwise, adding extra feature might increase the classification accuracy of the models with even single-axis features. The selected features include RMS, Variance, skewness, kurtosis, impulse factor and range. Info-GainAttributeEval was used to evaluate the worth of an attribute by measuring the information gain with respect to the fault class, using the Equation 6.2 below.

$$InfoGain(Class, Attribute) = H(Class) - H(Class|Attribute) \quad (6.2)$$

The method discretizes the numeric attributes employing supervised discretization method before evaluation using ranker method.

6.2.4 Fault Classification

During the supervised learning process, a classifier is trained and used to test unknown examples. Total 140 instances were fed to classifier, i.e. 70 for each

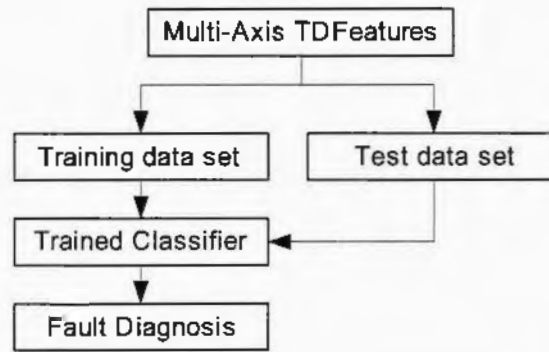

FIGURE 6.4: Fault classification procedure

fault. Figure 6.4 describes the fault classification process, where 10-fold cross validation method is used to train and test the unknown examples.

6.3 Results and Discussion

The literature shows that only single axis (radial or axial) vibration measurements are used to extract TD features, especially the radial axis vibrations. Importantly, the unbalance and misalignment faults may demonstrate different forces in radial and axial axes. Consequently, a TD feature can exhibit different sensitivity to both axes, when extracted from simultaneously captured vibration signals. Thus, the proposed study exploits multi-axis vibrations to extract TD features for supervised learning based recognition of fault patterns. In addition to incorporating features from both axes, every pair of alike features is then further processed to obtain very effective single feature. For instance, feature RMS-Radial and RMS-Axial are processed adequately to produce single RMS-Multiaxis feature. Apart from robustness, the simple feature processing method suits to our application because of maintaining the length of feature vector.

As discussed in Section 6.1, large amplitude at 1X in spectrum has been considered to detect rotor's unbalance fault. On the other hand, misalignment fault is supposed to produce high amplitude at 2X. However, due to emergence of new technologies, it has become easier to analyze the amplitudes of entire frequency

range in spectrum. The previous research reveals that most often the largest amplitude produced by misalignment may not be at 2X, but it may be at 1X instead. Therefore, unbalance has often been blamed for misalignment [37].

As discussed earlier, the rotor balancing procedure involves additional weight attachment or removal of extra weight. The rotor may exhibit unusual behavior, if applied the same treatment to address misalignment fault. Thus, accurate identification of these faults becomes very crucial. The task is not as simple using conventional frequency analysis methods, because both the faults can produce similar form of frequency patterns. To address this issue, this study investigated the diagnostic capability of multi-axis TD features, i.e. the TD features extracted from radial and axial vibration signals acquired simultaneously.

Table 6.1 shows 83.3% classification accuracy using six radial features, and 81.7% accuracy using six axial features. On the other hand, combining both kind of features (twelve multi-axis features), resulted in 100% accuracy. However, the vector length increased to twelve, and generally classifier's accuracy may be enhanced by increasing number of features [34]. Yet, the assumption was that utilization of both radial and axial features together enhances the fault identification of the classifier, as the unbalance force acts mainly towards radial direction whereas the angular misalignment force acts in both radial and axial direction. This phenomenon may cause variation in vibratory behavior between both axes, and consequently in the extracted features.

TABLE 6.1: Classification accuracies (%) demonstrated by SVM using radial, axial and multi-axis TD features

Radial	Axial	Multi-axis Combined	Multi-axis Processed
83.3	81.7	100	100
Features	Features	Features	Features
6	6	12	6

To validate the above stated hypothesis, every pair of alike features was then further processed to produce single feature, i.e. radial and axial features were

TABLE 6.2: Classification accuracies (%) demonstrated by every classifier using radial, axial and multi-axis TD features

Classifier	Radial	Axial	Multi-axis Processed	Features used
SVM	83.3	81.7	100	6
bayesNet	82.3	81.3	100	6
Decision Tree	82.6	82.1	100	6
Decision Table	83.1	81.1	100	6

processed adequately to produce single robust feature. As a result, a feature set of obtained having more diagnostic information. 100% accuracy for six multi-axis processed features is evident of the effectiveness and efficiency of the proposed method. Decision making capability of the classifier was improved by using multi-axis features comparing to single-axis features, especially after processing.

Other classifiers, i.e. bayesNet, decision table, and decision tree also provide 100% accuracy using only six processed multi-axis features. Whereas, all the classifiers show similar sort of performance using six radial or six axial features. For radial single-axis, the accuracies lie between 82.3% to 83.1% and for axial single-axis the accuracies lie in the range between 81.1% to 82.1%.

It is worth-mentioning that the sensitivity of TD features to different mechanical forces is utilized in a way that the decision making capability of the supervised learning based classifiers was enhanced considerably.

6.4 Summary

Unbalance and misalignment are the most commonly occurring faults in rotating machinery. It is very important to confirm the unbalanced state of rotor before maintenance because the balancing procedure of an unbalanced rotor is based on weight adjustment technique. Otherwise, the rotor may introduce additional problems in the machine. The task becomes difficult using conventional spectral analysis methods as both the faults can produce similar type of frequency patterns.

To solve the problem, this study exploited the difference of behavior exhibited by these faults in terms of vibration transmission in radial and axial directions. Combining the multi-axis TD features provides very accurate result. Furthermore, every pair of alike features were processed adequately to produce single robust feature. This enhanced the efficiency of the diagnostic model by maintaining the length of feature vector. All the classifiers provides 100% results using multi-axis processed TD features.

Chapter 7

Conclusions and Future Work

This thesis proposed and evaluated novel methods for diagnosis of faults in rotating machinery based on supervised machine learning techniques using vibration data. Obtaining accurate and fault-related TD statistical features was the focus of the study, with the intent to improve fault classification accuracy. As the rotating machinery components transmit complex and random vibration signals, this research emphasizes to use processed TD features to recognize fault patterns instead of using raw features directly. For instance, localized faults in REB produce very low amplitudes in vibration signals. The faults identification is therefore very difficult by using conventional frequency analysis methods. In addition, unrelated spikes or fluctuations transmitted by joint machinery components may easily alter the statistical values of the features. The affected features may not represent true fault conditions. This consequently mislead the classifiers and making the fault identification process very hard. The present study presented new CT-based feature processing and extraction methods for obtaining accurate features to aid the PR-based diagnostic process. Other case was concerned about rotor faults, which although produces stronger impacts in vibration signals but most common faults like unbalance and misalignment produce very similar sort of frequency spectra. Pattern identification of these faults using raw TD statistics may not be very effective again as the features can be sensitive to severity levels of these faults. The present research exploited the dissimilarity of mechanical forces produced by the

faults to extract multi-axis TD features from simultaneously captured radial and axial vibration signals. Adequate processing of these features prior to incorporate classifier greatly helped to improve the diagnostic capability of the classifier. Variety of classifiers were employed to evaluate the presented methodologies, and the results were evident that all the classifiers performed better when utilized TD features obtained through the proposed methods. The classifiers include SVM, bayesNet, decision table and decision tree.

Two new methods were presented to achieve trustworthy decision making for the identification of localized faults of REB. The CT-based feature processing methods adequately mitigate the affect of undesired fluctuations on PR-models. The first method is CTBFP, discussed in Chapter 3, that work at the feature-level i.e. data preparation stage of forming instances prior to incorporate classifier in the diagnostic model. The TD features were extracted from several vibration samples. Every feature distribution was put under test separately to check whether the feature contained one or more outlier values. In case any feature distribution contained any outlier, the whole instance was discarded from the data-set. This is analogous to discarding the specified vibration sample from which the TD features were extracted and isolating the unrelated machine components from the problem at hand. The CTBFP method took advantage of the sensitivity of TD features as they produce outliers indicating an inappropriate vibration sample to proceed on. The CTBFP is an efficient method and offered significant immunity to not only signal fluctuations but even background noises. Moreover, the statistical TD features have shown different levels of sensitivity to these randomly occurred fluctuations. The method produced 94.4% accuracy at maximum using the multi-class SVM to identify four faults of REB employing ten TD features. Whereas, the classifier could provide only 76.3% accuracy when employed the same raw TD features. Other classifiers demonstrated similar sort of difference in their performances using raw and processed features.

The other method is CTBFE which was discussed in Chapter 4. The presented method was used to identify bearing's localized faults. Unlike processing the feature distributions at feature-level, this method works at feature-extraction-level

rather to obtain reliable TD feature values. The CTBFE method overcome the inherited limitations of applying CTBFP method in situations where availability of data size is limited. The method does not discard the affected instances but utilized every available vibration sample. It selects the most appropriate portion or sub-sample of a vibration sample for the extraction of TD features. This strategy ensures the supply of very accurate feature values to a classifier for truthful decision making. In addition to efficiency, the presented method provided significant immunity to possible fluctuations and background noises in vibration signal. Apart from preserving number of instances, the CTBFE provided even more accurate results compared to that of CTBFP method. However, the CTBFP is more efficient when the availability of data is not restricted. The CTBFE demonstrated 96.8% accuracy at maximum using the multi-class SVM to identify four faults of REB employing ten TD features. Whereas, the classifier could provide only 76.3% accuracy when employed the same raw TD features. Both the above mentioned methods disassociated the effect of unrelated vibrations adequately from sensitive TD features before the start of supervised learning process. It is worth mentioning that only fewer values of features were required to processed than with conventional pre-processing techniques to enhance the fault classification accuracy.

The CTBFE method is exploited further to present a RBDS to identify localized faults in REB. The method utilized the accurate and stable feature values extracted through CTBFE method. The CTBFE-based feature values, acted as CVs, were obtained against the respective bearing faults. Distances between NCVs in the respective sets were employed to build a kind of feature selection mechanism, and to generate simple rule-set for the fault identification. The RBDS produced excellent results and offered an unique alternative to the existing PR-based fault diagnosis. The method produced 95.6% accurate results employing only three salient features.

Finally, the TD features were also processed to identify rotor's most common faults, such as unbalance and misalignment. Confirming the unbalanced state of rotor before the maintenance activity is important as balancing procedure is based on weight adjustment technique. Misjudging misalignment with unbalance may

lead to additional problems in machinery. This study exploited the difference of behavior exhibited by these faults in terms of vibration transmission in radial and axial directions. Combining the multi-axis TD features provides very accurate results. Every pair of alike features were processed adequately to produce again a single robust feature. The method enhanced the accuracy of the binary-SVM model to 100% using six multi-axis features only while maintaining the length of feature vector. Whereas, the classifier provides only 83.3% classification accuracy employing the single axis same TD features.

7.1 Future Work

- The CTBFP and CTBFE are applied to localized faults in REB. Due to providing very accurate results, the future research may continue to apply these methods to diagnose other faults in rotating machinery, for example gear faults. However, care must be taken before isolating the fault under investigation from any undesired data that any related and valuable information might not be lost.
- The CTBFP method processes the features efficiently via outlier detection by implementing the MOD function, discussed in Chapter 3. The affected instances were pruned at next stage of the algorithm based on the MOD outcome. The MOD's parameter *scale* determines the threshold to categorize any feature value as outlier. The parameter acts as trade-off between the resulting accuracy and the size of remaining data-set used in supervised learning process. The present research used a standard threshold value suggested in the literature due to limited resources. However, value of the parameter may be adjusted according to the nature of data-set or application of other rotating component of machinery. The future research should investigate the adaptive value of the *scale* parameter using some optimization technique before employing the MOD function for best results.

- Multi-axis TD features may also be applied to identify multiple rotor problems, i.e. in addition to unbalance and misalignment. The problems may include bent shaft, coupling problems, eccentricity etc. As the transmission of mechanical forces from these faults may vary, the phase information in vibration signals captured from multiple axes may be a useful tool to include as additional features for reliable distinction of the faults. Taking into account the phases as features may diagnose the above mentioned multiple rotor faults accurately, especially the spectra of which do not provide clear distinction.
- The presented methods are evaluated using supervised learning based fault classification techniques. The future research may apply these methods to investigate their effectiveness on un-supervised or semi-supervised learning based fault classification models.

References

- [1] V. Wowk, *Machinery Vibration: Measurement and Analysis*. New York, NY, USA: McGraw-Hill, 1991.
- [2] R. B. Randall, *Vibration-based condition monitoring : industrial, aerospace and automotive applications*. New York, NY, USA: Wiley, 2011.
- [3] A. K. Jardine, D. Lin, and D. Banjevic, "A review on machinery diagnostics and prognostics implementing condition-based maintenance," *Mechanical systems and signal processing*, vol. 20, no. 7, pp. 1483–1510, 2006.
- [4] N. Tandon and A. Choudhury, "A theoretical model to predict vibration response of rolling bearings to distributed defects under radial load," *Journal of Vibrations and Acoustics*, vol. 20, pp. 214–220, 1998.
- [5] M. W. Washo, "A quick method for determining root causes and corrective actions of failed ball bearings," *Lubrication engineering*, vol. 52, no. 3, pp. 206–213, 1996.
- [6] Q. Liu, F. Chen, Z. Zhou, and Q. Wei, "Fault diagnosis of rolling bearing based on wavelet package transform and ensemble empirical mode decomposition," *Advances in Mechanical Engineering*, vol. 5, p. 792584, 2013.
- [7] N. Tandon and A. Choudhury, "A review of vibration and acoustic measurement methods for the detection of defects in rolling element bearings," *Tribology international*, vol. 32, no. 8, pp. 469–480, 1999.

- [8] S. Singh and N. Kumar, "Rotor faults diagnosis using artificial neural networks and support vector machines," *International Journal of Acoustics and Vibration*, vol. 20, no. 3, pp. 153–159, 2014.
- [9] C. D. Bocaniala and V. Palade, "Computational intelligence methodologies in fault diagnosis: review and state of the art," in *Computational intelligence in fault diagnosis*. Springer, 2006, pp. 1–36.
- [10] T. W. Rauber, E. M. do Nascimento, E. D. Wandekokem, and F. M. Varejão, *Pattern Recognition based Fault Diagnosis in Industrial Processes: Review and Application*, adam herout ed. INTECH Open Access Publisher, 2010.
- [11] S. Ericsson, N. Grip, E. Johansson, L.-E. Persson, R. Sjöberg, and J.-O. Strömberg, "Towards automatic detection of local bearing defects in rotating machines," *Mechanical systems and signal processing*, vol. 19, no. 3, pp. 509–535, 2005.
- [12] N. Sawalhi, R. Randall, and H. Endo, "The enhancement of fault detection and diagnosis in rolling element bearings using minimum entropy deconvolution combined with spectral kurtosis," *Mechanical Systems and Signal Processing*, vol. 21, no. 6, pp. 2616 – 2633, 2007.
- [13] J. Antoni, "Fast computation of the kurtogram for the detection of transient faults," *Mechanical Systems and Signal Processing*, vol. 21, no. 1, pp. 108–124, 2007.
- [14] E. Bechhoefer and P. Menon, "Bearing envelope analysis window selection," in *Annual Conference of the Prognostics and Health Management Society*, 2009, pp. 1–7.
- [15] T. Barszcz and A. Jabłoński, "Selected methods of finding optimal center frequency for amplitude demodulation of vibration signals," *Diagnostyka*, pp. 25–28, 2010.

- [16] W. Wang and H. Lee, "An energy kurtosis demodulation technique for signal denoising and bearing fault detection," *Measurement Science and Technology*, vol. 24, no. 2, p. 025601, 2013.
- [17] M. Zhao, J. Lin, X. Xu, and X. Li, "Multi-fault detection of rolling element bearings under harsh working condition using imf-based adaptive envelope order analysis," *Sensors*, vol. 14, no. 11, pp. 20 320–20 346, 2014.
- [18] W. Caesarendra, P. Kosasih, A. Tieu, C. Moodie, and B.-K. Choi, "Condition monitoring of naturally damaged slow speed slewing bearing based on ensemble empirical mode decomposition," *Journal of Mechanical Science and Technology*, vol. 27, no. 8, pp. 2253–2262, 2013.
- [19] X. Lou and K. A. Loparo, "Bearing fault diagnosis based on wavelet transform and fuzzy inference," *Mechanical Systems and Signal Processing*, vol. 18, no. 5, pp. 1077 – 1095, 2004.
- [20] C. Smith, C. M. Akujuobi, P. Hamory, and K. Kloesel, "An approach to vibration analysis using wavelets in an application of aircraft health monitoring," *Mechanical Systems and Signal Processing*, vol. 21, no. 3, pp. 1255 – 1272, 2007.
- [21] V. Purushotham, S. Narayanan, and S. A. Prasad, "Multi-fault diagnosis of rolling bearing elements using wavelet analysis and hidden markov model based fault recognition," *NDT and E International*, vol. 38, no. 8, pp. 654 – 664, 2005.
- [22] J. Altmann and J. Mathew, "Multiple bandpass autoregressive demodulation for rolling-element bearing fault diagnosis," *Mechanical Systems and Signal Processing*, vol. 15, no. 5, pp. 963 – 977, 2001.
- [23] S. Abbasion, A. Rafsanjani, A. Farshidianfar, and N. Irani, "Rolling element bearings multi-fault classification based on the wavelet denoising and support vector machine," *Mechanical Systems and Signal Processing*, vol. 21, no. 7, pp. 2933 – 2945, 2007.

- [24] H. Lee, C. Byington, and M. Watson, "Phm system enhancement through noise reduction and feature normalization," in *Aerospace Conference, 2010 IEEE*. IEEE, 2010, pp. 1–10.
- [25] M. Watson, M. Begin, S. Amin, J. Sheldon, H. Lee, and C. Byington, "A comprehensive high frequency vibration monitoring system for incipient fault detection and isolation in gears, bearings and shafts/couplings in turbine engines and accessories," in *Proceedings of the ASME Turbo Expo, 2007*, pp. 885–894.
- [26] B. Samanta, K. Al-Balushi, and S. Al-Araimi. "Artificial neural networks and support vector machines with genetic algorithm for bearing fault detection," *Engineering Applications of Artificial Intelligence*, vol. 16, no. 78, pp. 657 – 665, 2003.
- [27] L. Jack and A. Nandi, "Fault detection using support vector machines and artificial neural networks, augmented by genetic algorithms," *Mechanical Systems and Signal Processing*, vol. 16, no. 23, pp. 373 – 390, 2002.
- [28] A. Rojas and A. K. Nandi, "Practical scheme for fast detection and classification of rolling-element bearing faults using support vector machines," *Mechanical Systems and Signal Processing*, vol. 20, no. 7, pp. 1523 – 1536, 2006.
- [29] B. Samanta and K. Al-Balushi, "Artificial neural network based fault diagnostics of rolling element bearings using time-domain features," *Mechanical Systems and Signal Processing*, vol. 17, no. 2, pp. 317 – 328, 2003.
- [30] B. S. Yang, T. Han, and J. L. An, "ARTKOHONEN neural network for fault diagnosis of rotating machinery," *Mechanical Systems and Signal Processing*, vol. 18, no. 3, pp. 645–657, 2004.
- [31] L. Zhang, L. B. Jack, and A. K. Nandi, "Fault detection using genetic programming," *Mechanical Systems and Signal Processing*, vol. 19, no. 2, pp. 271 – 289, 2005.

- [32] V. Sugumaran and K. Ramachandran, "Automatic rule learning using decision tree for fuzzy classifier in fault diagnosis of roller bearing," *Mechanical Systems and Signal Processing*, vol. 21, no. 5, pp. 2237–2247, 2007.
- [33] P. Kankar, S. C. Sharma, and S. Harsha, "Fault diagnosis of ball bearings using machine learning methods," *Expert Systems with Applications*, vol. 38, no. 3, pp. 1876–1886, 2011.
- [34] V. Sugumaran and K. I. Ramachandran, "Effect of number of features on classification of roller bearing faults using svm and psvm," *Expert Systems with Applications*, vol. 38, no. 4, pp. 4088–4096, 2011.
- [35] M. Saimurugan, K. I. Ramachandran, V. Sugumaran, and N. R. Sakthivel, "Multi component fault diagnosis of rotational mechanical system based on decision tree and support vector machine," *Expert Systems with Applications*, vol. 38, no. 4, pp. 3819–3826, 2011.
- [36] A. Jalan and A. Mohanty, "Model based fault diagnosis in rotating machinery," *International Journal of Performability Engineering*, vol. 7, no. 6, pp. 515–523, 2011.
- [37] Ralph T. Buscarello, *Practical Solutions to Machinery and Maintenance Vibration Problems*. USA: Update International, 1977, accessed on 11 May, 2016. [Online]. Available: <http://updateinternational.com/Book/VibrationBook.htm>
- [38] V. N. Vapnik and V. Vapnik, *Statistical learning theory*. New York, NY, USA: Wiley, 1998, vol. 1.
- [39] H. Kirsch and K. Kroschel, "Applying bayesian networks to fault diagnosis," in *Control Applications, Proceedings of the Third IEEE Conference*, vol. 2, Aug 1994, pp. 895–900.
- [40] R. Kohavi, "The power of decision tables," in *European conference on machine learning*. Springer, 1995, pp. 174–189.

- [41] J. R. Quinlan, "Induction of decision trees," *Machine learning*, vol. 1, no. 1, pp. 81–106, 1986.
- [42] P. Jayaswal, A. Wadhvani, and K. Mulchandani, "Machine fault signature analysis," *International Journal of Rotating Machinery*, vol. 2008, 2008.
- [43] A. Heng, S. Zhang, A. C. Tan, and J. Mathew, "Rotating machinery prognostics: State of the art, challenges and opportunities," *Mechanical Systems and Signal Processing*, vol. 23, no. 3, pp. 724 – 739, 2009. [Online]. Available: <http://www.sciencedirect.com/science/article/pii/S0888327008001489>
- [44] Y. Chinniah, "Analysis and prevention of serious and fatal accidents related to moving parts of machinery," *Safety Science*, vol. 75, no. Supplement C, pp. 163 – 173, 2015. [Online]. Available: <http://www.sciencedirect.com/science/article/pii/S0925753515000326>
- [45] E. P. Carden and P. Fanning, "Vibration based condition monitoring: a review," *Structural health monitoring*, vol. 3, no. 4, pp. 355–377, 2004.
- [46] S. Orhan, N. Aktürk, and V. Celik, "Vibration monitoring for defect diagnosis of rolling element bearings as a predictive maintenance tool: Comprehensive case studies," *Ndt & E International*, vol. 39, no. 4, pp. 293–298, 2006.
- [47] C. Sheng, Z. Li, L. Qin, Z. Guo, and Y. Zhang, "Recent progress on mechanical condition monitoring and fault diagnosis," *Procedia Engineering*, vol. 15, pp. 142–146, 2011.
- [48] A. Boudiaf, A. Djebala, H. Bendjma, A. Balaska, and A. Dahane, "A summary of vibration analysis techniques for fault detection and diagnosis in bearing," in *Modelling, Identification and Control (ICMIC), 2016 8th International Conference on*. IEEE, 2016, pp. 37–42.
- [49] A. Parkinson, "Balancing of rotating machinery," *Proceedings of the Institution of Mechanical Engineers, Part C: Mechanical Engineering Science*, vol. 205, no. 1, pp. 53–66, 1991.

- [50] W. Foiles, P. Allaire, and E. Gunter, "Review: rotor balancing," *Shock and Vibration*, vol. 5, no. 5-6, pp. 325-336, 1998.
- [51] S. Nandi, H. A. Toliyat, and X. Li, "Condition monitoring and fault diagnosis of electrical motors: a review." *IEEE transactions on energy conversion*, vol. 20, no. 4, pp. 719-729, 2005.
- [52] A. Sekhar and B. Prabhu, "Effects of coupling misalignment on vibrations of rotating machinery," *Journal of Sound and vibration*, vol. 185, no. 4, pp. 655-671, 1995.
- [53] F. Ehrich, *Handbook of Rotordynamics*. McGraw Hill, NY, 1992.
- [54] A. Lees and M. Friswell, "The evaluation of rotor imbalance in flexibly mounted machines," *Journal of Sound and Vibration*, vol. 208, no. 5, pp. 671-683, 1997.
- [55] M. Jordan, "What are orbit plots, anyway," *Orbit*, vol. 14, no. 4, pp. 8-15, 1993.
- [56] T. H. Patel and A. K. Darpe, "Vibration response of misaligned rotors," *Journal of sound and vibration*, vol. 325, no. 3, pp. 609-628, 2009.
- [57] J. Gertler, *Fault detection and diagnosis in engineering systems*. CRC press, 1998.
- [58] K. Kim and A. G. Parlos, "Induction motor fault diagnosis based on neuropredictors and wavelet signal processing," *IEEE/ASME Transactions on mechatronics*, vol. 7, no. 2, pp. 201-219, 2002.
- [59] E. Sobhani-Tehrani and K. Khorasani, *Fault diagnosis of nonlinear systems using a hybrid approach*. Springer Science & Business Media, 2009, vol. 383.
- [60] Y.-T. Su and S.-J. Lin, "On initial fault detection of a tapered roller bearing: frequency domain analysis," *Journal of Sound and Vibration*, vol. 155, no. 1, pp. 75-84, 1992.

- [61] X. Zhao, M. J. Zuo, and R. Moghaddass, "Generating indicators for diagnosis of fault levels by integrating information from two or more sensors," *Diagnostics and Prognostics of Engineering Systems: Methods and Techniques: Methods and Techniques*, p. 74, 2012.
- [62] W. Fengqi and G. Meng, "Compound rub malfunctions feature extraction based on full-spectrum cascade analysis and svm," *Mechanical systems and signal processing*, vol. 20, no. 8, pp. 2007–2021, 2006.
- [63] T. H. Patel and A. K. Darpe, "Vibration response of a cracked rotor in presence of rotor–stator rub," *Journal of Sound and Vibration*, vol. 317, no. 3, pp. 841–865, 2008.
- [64] C. J. Li and J. Limmer, "Model-based condition index for tracking gear wear and fatigue damage," *Wear*, vol. 241, no. 1, pp. 26–32, 2000.
- [65] J. Antoni, F. Bonnardot, A. Raad, and M. El Badaoui, "Cyclostationary modelling of rotating machine vibration signals," *Mechanical systems and signal processing*, vol. 18, no. 6, pp. 1285–1314, 2004.
- [66] Y. Jia, J. Henao-Sepulveda, and M. Toledo-Quinones, "Wireless temperature sensor for bearing health monitoring," in *Smart Structures and Materials*. International Society for Optics and Photonics, 2004, pp. 368–376.
- [67] L. Rende and T. Dehua, "Using oil analysis to study the wear condition of bearing in trunnion of converter during/after run-in period," in *Proceedings of the 5th International Conference on Quality, Reliability and Maintenance QRM 2004*, 2004, pp. 101–104.
- [68] M. E. H. Benbouzid, "A review of induction motors signature analysis as a medium for faults detection," *IEEE transactions on industrial electronics*, vol. 47, no. 5, pp. 984–993, 2000.
- [69] A. M. Al-Ghamd and D. Mba, "A comparative experimental study on the use of acoustic emission and vibration analysis for bearing defect identification

- and estimation of defect size,” *Mechanical systems and signal processing*, vol. 20, no. 7, pp. 1537–1571, 2006.
- [70] R. Heng and M. J. M. Nor, “Statistical analysis of sound and vibration signals for monitoring rolling element bearing condition,” *Applied Acoustics*, vol. 53, no. 1-3, pp. 211–226, 1998.
- [71] R. B. Randall, J. Antoni, and S. Chobsaard, “The relationship between spectral correlation and envelope analysis in the diagnostics of bearing faults and other cyclostationary machine signals,” *Mechanical systems and signal processing*, vol. 15, no. 5, pp. 945–962, 2001.
- [72] Q. Du and S. Yang, “Improvement of the emd method and applications in defect diagnosis of ball bearings,” *Measurement Science and Technology*, vol. 17, no. 8, p. 2355, 2006.
- [73] B. Tao, L. Zhu, H. Ding, and Y. Xiong, “Rényi entropy-based generalized statistical moments for early fatigue defect detection of rolling-element bearing,” *Proceedings of the Institution of Mechanical Engineers, Part C: Journal of Mechanical Engineering Science*, vol. 221, no. 1, pp. 67–79, 2007.
- [74] J. J. Carbajal-Hernández, L. P. Sánchez-Fernández, I. Hernández-Bautista, J. d. J. Medel-Juárez, and L. A. Sánchez-Pérez, “Classification of unbalance and misalignment in induction motors using orbital analysis and associative memories,” *Neurocomputing*, vol. 175, pp. 838–850, 2016.
- [75] S. A. Teukolsky, B. P. Flannery, W. Press, and W. Vetterling, “Numerical recipes in c,” *SMR*, vol. 693, p. 1, 1992.
- [76] I. Standard, “Mechanical vibration-evaluation of machine vibration by measurements on non-rotating parts,” *ISO/IS*, vol. 10816, 1996.
- [77] R. R. Obaid, T. G. Habetler, and R. M. Tallam, “Detecting load unbalance and shaft misalignment using stator current in inverter-driven induction motors,” in *Electric Machines and Drives Conference, 2003. IEMDC'03. IEEE International*, vol. 3. IEEE, 2003, pp. 1454–1458.

- [78] D. Zhen, T. Wang, F. Gu, and A. Ball, "Fault diagnosis of motor drives using stator current signal analysis based on dynamic time warping," *Mechanical Systems and Signal Processing*, vol. 34, no. 1, pp. 191–202, 2013.
- [79] R. Kechida, A. Menacer, and H. Talhaoui, "Approach signal for rotor fault detection in induction motors," *Journal of failure analysis and prevention*, vol. 13, no. 3, pp. 346–352, 2013.
- [80] M. P. Norton and D. G. Karczub, *Fundamentals of noise and vibration analysis for engineers*. Cambridge university press, 2003.
- [81] A. V. Oppenheim and R. W. Schaffer, "From frequency to quefrequency: A history of the cepstrum," *IEEE signal processing Magazine*, vol. 21, no. 5, pp. 95–106, 2004.
- [82] F. E. H. Montero and O. C. Medina, "The application of bispectrum on diagnosis of rolling element bearings: A theoretical approach," *Mechanical Systems and Signal Processing*, vol. 22, no. 3, pp. 588–596, 2008.
- [83] A. McCormick and A. K. Nandi, "Bispectral and trispectral features for machine condition diagnosis," *IEE Proceedings-Vision, Image and Signal Processing*, vol. 146, no. 5, pp. 229–234, 1999.
- [84] L. Qiu, X. Liu, G. Peyronne, and Y. Chen, "The holospectrum: a new method for rotor surveillance and diagnosis," *Mechanical systems and signal processing*, vol. 3, no. 3, pp. 255–267, 1989.
- [85] A. Brandt, *Noise and vibration analysis: signal analysis and experimental procedures*. John Wiley & Sons, 2011.
- [86] D. Ho and R. Randall, "Optimisation of bearing diagnostic techniques using simulated and actual bearing fault signals," *Mechanical systems and signal processing*, vol. 14, no. 5, pp. 763–788, 2000.
- [87] D. Howieson, "Vibration monitoring: Envelope signal processing," *Diagnostic instruments, SKF Reliability Systems*, 2003.

- [88] J. Antoni, "Matlab code to compute signal's fast kurtogram," 2014, accessed on 25th July, 2015. [Online]. Available: https://www.mathworks.com/matlabcentral/fileexchange/48912-fast-kurtogram/content/Fast_kurtogram.m
- [89] T. Kaewkongka, Y. Joe, R. Rakowski, and B. Jones, "A comparative study of short time fourier transform and continuous wavelet transform for bearing condition monitoring," *International Journal of COMADEM*, vol. 6, no. 1, pp. 41–48, 2003.
- [90] Z. Peng and F. Chu, "Application of the wavelet transform in machine condition monitoring and fault diagnostics: a review with bibliography," *Mechanical systems and signal processing*, vol. 18, no. 2, pp. 199–221, 2004.
- [91] B. Kim, S. Lee, M. Lee, J. Ni, J. Song, and C. Lee, "A comparative study on damage detection in speed-up and coast-down process of grinding spindle-typed rotor-bearing system," *Journal of materials processing technology*, vol. 187, pp. 30–36, 2007.
- [92] A. Soualhi, K. Medjaher, and N. Zerhouni, "Bearing health monitoring based on hilbert–huang transform, support vector machine, and regression," *IEEE Transactions on Instrumentation and Measurement*, vol. 64, no. 1, pp. 52–62, 2015.
- [93] H. Li, H. Zheng, and L. Tang, "Bearing fault detection and diagnosis based on teager–huang transform," *International Journal of Wavelets, Multiresolution and Information Processing*, vol. 7, no. 05, pp. 643–663, 2009.
- [94] Z. Feng, M. Liang, and F. Chu, "Recent advances in time–frequency analysis methods for machinery fault diagnosis: a review with application examples," *Mechanical Systems and Signal Processing*, vol. 38, no. 1, pp. 165–205, 2013.
- [95] P. K. Kankar, S. C. Sharma, and S. P. Harsha, "Fault diagnosis of ball bearings using continuous wavelet transform," *Applied Soft Computing*, vol. 11, no. 2, pp. 2300–2312, 2011.

- [96] S. Prabhakar, A. Mohanty, and A. Sekhar, "Application of discrete wavelet transform for detection of ball bearing race faults," *Tribology International*, vol. 35, no. 12, pp. 793–800, 2002.
- [97] N. Nikolaou and I. Antoniadis, "Rolling element bearing fault diagnosis using wavelet packets," *Ndt & E International*, vol. 35, no. 3, pp. 197–205, 2002.
- [98] D. Yang, "Induction motor bearing fault diagnosis using hilbert-based bispectral analysis," in *Computer, Consumer and Control (IS3C), 2012 International Symposium on*. IEEE, 2012, pp. 385–388.
- [99] V. Climente-Alarcon, J. Antonino-Daviu, M. Riera-Guasp, R. Puche-Panadero, and L. Escobar, "Application of the wigner–ville distribution for the detection of rotor asymmetries and eccentricity through high-order harmonics," *Electric Power Systems Research*, vol. 91, pp. 28–36, 2012.
- [100] D. Liu, Y. Zhao, B. Yang, and J. Sun, "A new motor fault detection method using multiple window s-method time-frequency analysis," in *Systems and Informatics (ICSAI), 2012 International Conference on*. IEEE, 2012, pp. 2563–2566.
- [101] J. Antoni, "The spectral kurtosis: a useful tool for characterising non-stationary signals," *Mechanical Systems and Signal Processing*, vol. 20, no. 2, pp. 282–307, 2006.
- [102] J. Antoni and R. Randall, "The spectral kurtosis: application to the vibratory surveillance and diagnostics of rotating machines," *Mechanical Systems and Signal Processing*, vol. 20, no. 2, pp. 308–331, 2006.
- [103] P. Borghesani, R. Ricci, S. Chatterton, and P. Pennacchi, "A new procedure for using envelope analysis for rolling element bearing diagnostics in variable operating conditions," *Mechanical Systems and Signal Processing*, vol. 38, no. 1, pp. 23–35, 2013.

- [104] F. Hlawatsch and G. F. Boudreaux-Bartels, "Linear and quadratic time-frequency signal representations," *IEEE signal processing magazine*, vol. 9, no. 2, pp. 21–67, 1992.
- [105] Tony DeMatteo, "Phase analysis: Making vibration analysis easier."
- [106] D. Zhang and F. Xi, "Pattern recognition for automatic machinery fault diagnosis," 2004.
- [107] K. Worden and J. M. Dulieu-Barton, "An overview of intelligent fault detection in systems and structures," *Structural Health Monitoring*, vol. 3, no. 1, pp. 85–98, 2004.
- [108] R. Eisemann, *Machinery malfunction diagnosis and correction: Vibration analysis and troubleshooting for process industries*. Prentice Hall, Old Tappan, NJ (United States), 1998.
- [109] A. R. Crawford and S. Crawford, *The Simplified Handbook of Vibration Analysis. V. 1, Introduction to Vibration Analysis Fundamentals*. Computational Systems Incorporated, 1992.
- [110] N. Kirianaki, S. Yurish, N. Shpak, and V. Deynega, *Data acquisition and signal processing for smart sensors*. John Wiley & Sons, Chichester, 2002.
- [111] R. E. Kalman *et al.*, "A new approach to linear filtering and prediction problems," *Journal of basic Engineering*, vol. 82, no. 1, pp. 35–45, 1960.
- [112] B. Widrow, S. D. Stearns, and J. C. Burgess, "Adaptive signal processing edited by bernard widrow and samuel d. stearns," *The Journal of the Acoustical Society of America*, vol. 80, no. 3, pp. 991–992, 1986.
- [113] F. Al-Badour, M. Sunar, and L. Cheded, "Vibration analysis of rotating machinery using time–frequency analysis and wavelet techniques," *Mechanical Systems and Signal Processing*, vol. 25, no. 6, pp. 2083–2101, 2011.
- [114] K. Singh and S. Upadhyaya, "Outlier detection: applications and techniques," *International Journal of Computer Science Issues*, vol. 9, no. 1, pp. 307–323, 2012.

- [115] H.-P. Kriegel, P. Kröger, and A. Zimek, “Outlier detection techniques,” in *Tutorial at the 16th ACM International Conference on Knowledge Discovery and Data Mining (SIGKDD), Washington, DC*, 2010.
- [116] M. Agyemang, K. Barker, and R. Alhajj, “A comprehensive survey of numeric and symbolic outlier mining techniques,” *Intelligent Data Analysis*, vol. 10, no. 6, pp. 521–538, 2006.
- [117] V. Hodge and Austin, “A survey of outlier detection methodologies,” *Artificial Intelligence Review*, vol. 22, no. 2, pp. 85–126, 2004.
- [118] M. Markou and Singh, “Novelty detection: a review-part 1: statistical approaches,” *Signal Processing*, vol. 83, no. 12, pp. 2481–2497, 2003a.
- [119] Markou, M. and Singh, “Novelty detection: a review-part 2: neural network based approaches,” *Signal Processing*, vol. 83, no. 12, pp. 2499–2521, 2003b.
- [120] V. Chandola, A. Banerjee, and V. Kumar, “Outlier detection: A survey,” *ACM Computing Surveys*, 2007.
- [121] J. Zhang, “Advancements of outlier detection: A survey,” *ICST Transactions on Scalable Information Systems*, vol. 13, no. 1, pp. 1–26, 2013.
- [122] P.-N. Tan, M. Steinbach, and V. Kumar, *Introduction to Data Mining*. Addison-Wesley Longman Publishing Co., Inc., 2005.
- [123] Tukey, John W, *Exploratory Data Analysis*. USA: Addison-Wesley, 1977.
- [124] H. Yang, J. Mathew, and L. Ma, “Vibration feature extraction techniques for fault diagnosis of rotating machinery: a literature survey,” in *In Asia-Pacific Vibration Conference, Gold Coast, Australia*, 2003.
- [125] K. Worden, W. J. Staszewski, and J. J. Hensman, “Natural computing for mechanical systems research: A tutorial overview,” *Mechanical Systems and Signal Processing*, vol. 25, no. 1, pp. 4–111, 2011.

- [126] E. M. Knorr and R. T. Ng, "Algorithms for mining distance-based outliers in large datasets," in *Proceedings of the International Conference on Very Large Data Bases*. Citeseer, 1998, pp. 392–403.
- [127] M. Ester, H.-P. Kriegel, J. Sander, and X. Xu, "A density-based algorithm for discovering clusters in large spatial databases with noise." in *Proceedings of 2nd International Conference of Knowledge Discovery and Data Mining*, vol. 96, no. 34, 1996, pp. 226–231.
- [128] D. M. Rocke and D. L. Woodruff, "Identification of outliers in multivariate data," *Journal of the American Statistical Association*, vol. 91, no. 435, pp. 1047–1061, 1996.
- [129] M. M. Tahir, A. Q. Khan, N. Iqbal, A. Hussain, and S. Badshah, "Enhancing fault classification accuracy of ball bearing using central tendency based time domain features," *IEEE Access*, vol. 5, pp. 72–83, 2017.
- [130] I. Guyon and A. Elisseeff, "An introduction to variable and feature selection," *Journal of machine learning research*, vol. 3, no. Mar, pp. 1157–1182, 2003.
- [131] J. H. Friedman and W. Stuetzle, "Projection pursuit regression," *Journal of the American statistical Association*, vol. 76, no. 376, pp. 817–823, 1981.
- [132] J. B. Tenenbaum, V. De Silva, and J. C. Langford, "A global geometric framework for nonlinear dimensionality reduction," *Science*, vol. 290, no. 5500, pp. 2319–2323, 2000.
- [133] Y. Sacys, I. Inza, and P. Larrañaga, "A review of feature selection techniques in bioinformatics," *Bioinformatics*, vol. 23, no. 19, pp. 2507–2517, 2007.
- [134] M. Kudo and J. Sklansky, "Comparison of algorithms that select features for pattern classifiers," *Pattern recognition*, vol. 33, no. 1, pp. 25–41, 2000.
- [135] H.-T. Lin, "From ordinal ranking to binary classification," Ph.D. dissertation, California Institute of Technology, 2008.

- [136] D. Wang, S. Sun, and W. T. Peter, "A general sequential monte carlo method based optimal wavelet filter: A bayesian approach for extracting bearing fault features," *Mechanical Systems and Signal Processing*, vol. 52, pp. 293–308, 2015.
- [137] C. Mechefske and J. Mathew, "Fault detection and diagnosis in low speed rolling element bearings part ii: The use of nearest neighbour classification," *Mechanical Systems and Signal Processing*, vol. 6, no. 4, pp. 309–316, 1992.
- [138] R. Casimir, E. Boutleux, G. Clerc, and A. Yahoui, "The use of features selection and nearest neighbors rule for faults diagnostic in induction motors," *Engineering Applications of Artificial Intelligence*, vol. 19, no. 2, pp. 169–177, 2006.
- [139] M. D. Prieto, G. Cirrincione, A. G. Espinosa, J. A. Ortega, and H. Henao, "Bearing fault detection by a novel condition-monitoring scheme based on statistical-time features and neural networks," *IEEE Transactions on Industrial Electronics*, vol. 60, no. 8, pp. 3398–3407, 2013.
- [140] B.-S. Yang, T. Han, and W.-W. Hwang, "Fault diagnosis of rotating machinery based on multi-class support vector machines," *Journal of Mechanical Science and Technology*, vol. 19, no. 3, pp. 846–859, 2005.
- [141] A. Widodo and B.-S. Yang, "Support vector machine in machine condition monitoring and fault diagnosis," *Mechanical systems and signal processing*, vol. 21, no. 6, pp. 2560–2574, 2007.
- [142] C. Shen, D. Wang, F. Kong, and W. T. Peter, "Fault diagnosis of rotating machinery based on the statistical parameters of wavelet packet paving and a generic support vector regressive classifier," *Measurement*, vol. 46, no. 4, pp. 1551–1564, 2013.
- [143] X. Liu, L. Ma, and J. Mathew, "Machinery fault diagnosis based on fuzzy measure and fuzzy integral data fusion techniques," *Mechanical Systems and Signal Processing*, vol. 23, no. 3, pp. 690–700, 2009.

- [144] E. Zio, P. Baraldi, and G. Gola, "Feature-based classifier ensembles for diagnosing multiple faults in rotating machinery," *Applied soft computing*, vol. 8, no. 4, pp. 1365–1380, 2008.
- [145] L. Zhang, G. Xiong, H. Liu, H. Zou, and W. Guo, "Bearing fault diagnosis using multi-scale entropy and adaptive neuro-fuzzy inference," *Expert Systems with Applications*, vol. 37, no. 8, pp. 6077–6085, 2010.
- [146] M. Woźniak, M. Graña, and E. Corchado, "A survey of multiple classifier systems as hybrid systems," *Information Fusion*, vol. 16, pp. 3–17, 2014.
- [147] C. F. Sun, Z. S. Duan, Y. Yang, M. Wang, and L. J. Hu, "The motor fault diagnosis based on neural network and the theory of DS evidence," in *Advanced Materials Research*, vol. 683. Trans Tech Publ, 2013, pp. 881–884.
- [148] Z. Li, J. Zhu, X. Shen, C. Zhang, and J. Guo, "Fault diagnosis of motor bearing based on the bayesian network," *Procedia Engineering*, vol. 16, pp. 18–26, 2011.
- [149] T. P. Banerjee and S. Das, "Multi-sensor data fusion using support vector machine for motor fault detection," *Information Sciences*, vol. 217, pp. 96–107, 2012.
- [150] A. Verma, S. Sarangi, and M. H. Kolekar, "Stator winding fault prediction of induction motors using multiscale entropy and grey fuzzy optimization methods," *Computers & Electrical Engineering*, vol. 40, no. 7, pp. 2246–2258, 2014.
- [151] F. Zidani, M. E. H. Benbouzid, D. Diallo, and M. S. Naït-Saïd, "Induction motor stator faults diagnosis by a current concordia pattern-based fuzzy decision system," *IEEE Transactions on Energy Conversion*, vol. 18, no. 4, pp. 469–475, 2003.
- [152] Gareth Forbes, "Inner race and outer race faults vibration data using machine fault simulator," 2012, accessed on 30 June, 2014. [Online]. Available: <http://data-acoustics.com/measurements/bearing-faults/bearing-1/>